

**LEARNING MATERIAL OF
ADVANCE MANUFACTURING PROCESS
PREPARED BY – ER. SUBHASMITA JENA
&
ER. RASBIHARI SAHU**

ADVANCE MANUFACTURING PROCESSES

Modern Machining Processes:

- ❖ Introduction – comparison with traditional machining.
- ❖ Ultrasonic Machining: principle, Description of equipment, applications.
- ❖ Electric Discharge Machining: Principle, Description of equipment, Dielectric fluid, tools (electrodes), Process parameters, Output characteristics, applications.
- ❖ Wire cut EDM: Principle, Description of equipment, controlling parameters; applications.
- ❖ Abrasive Jet Machining: principle, description of equipment, Material removal rate, application.
- ❖ Laser Beam Machining: principle, description of equipment, Material removal rate, application.
- ❖ Electro Chemical Machining: principle, description of equipment, Material removal rate, application.
- ❖ Plasma Arc Machining – principle, description of equipment, Material removal rate, Process parameters, performance characterization, Applications.
- ❖ Electron Beam Machining - principle, description of equipment, Material removal rate, Process parameters, performance characterization, Applications.

Additive Manufacturing Process:

- ❖ Introduction, Need for Additive Manufacturing
- ❖ Fundamentals of Additive Manufacturing, AM Process Chain
- ❖ Advantages and Limitations of AM, Commonly used Terms
- ❖ Classification of AM process, Fundamental Automated Processes, Distinction between AM and CNC, other related technologies. Application –Application in Design, Aerospace Industry, Automotive Industry, Jewelry Industry, Arts and Architecture. RP Medical and Bioengineering Applications.

ADVANCE MANUFACTURING PROCESSES

❖ 1 COURSE OUTCOMES

The course consists of all non-conventional manufacturing processes. It starts with classification of manufacturing processes and necessity of non-conventional manufacturing processes. This course dealt with details about the mechanism of material removal, sources of energy used for material removal, working principle, the set up or equipment and relative advantages and disadvantages. It gives a clear cut idea about the processes, its use in specific industrial application etc.

Module I

Modern or Non Traditional Manufacturing Processes

Modern or Non-traditional manufacturing processes is defined as a group of processes that remove excess material by various techniques involving mechanical, thermal, electrical or chemical energy or combinations of these energies but do not use a sharp cutting tools as it needs to be used for traditional manufacturing processes.

Extremely hard and brittle materials are difficult to machine by traditional machining processes such as turning, drilling, shaping and milling. Non-traditional machining processes, also called advanced manufacturing processes, are employed where traditional machining processes are not feasible, satisfactory or economical due to special reasons as outlined below.

- Very hard fragile materials difficult to clamp for traditional machining
- When the workpiece is too flexible or slender
- When the shape of the part is too complex

Several types of non-traditional machining processes have been developed to meet extra required machining conditions. When these processes are

ADVANCE MANUFACTURING PROCESSES

employed properly, they offer many advantages over non-traditional machining processes. The common non-traditional machining processes are described in this section.

Modern manufacturing processes are classified according to the type of fundamental machining energy employed. A detail classification of the machining process based on the type of energy used, the mechanism of metal removal, the source of energy requirements etc is given below:

Classification of machining processes

Type of Energy	Mechanism of Metal Removal	Transfer Media	Energy source	Processes
Mechanical	Erosion	High velocity particle	Pneumatic/Hydraulic pressure	AJM, USM, WJM
	Shear	Physical contact	Cutting tool	Conventional machining
Electro chemical	Ion displacement	Electrolyte	High current	ECM, ECG
Chemical	Ablative relation	Reactive environment	Corrosive agent	CHM
Thermoelectric	Fusion	Hot gases	Ionized material	IBM, PAM
		Electrons	High voltage	EDM
	Vaporization	Radiation	Amplified light	LBM
		Ion stream	Ionized material	PAM

AJM: Abrasive Jet Machining

CHM:Chemical machining ECG:

Electrochemical Grinding

ECM:Electrochemical Machining

EDM:Electro Discharge Machining

ADVANCE MANUFACTURING PROCESSES

IBM: Ion Beam Machining LBM:

Laser Beam Machining PAM: Plasma

Arc Machining USM: Ultrasonic

Machining WJM: Water Jet

Machining

ULTRASONIC MACHINING (USM):

USM is mechanical material removal process or an abrasive process used to erode holes or cavities on hard or brittle workpiece by using shaped tools, high frequency mechanical motion and an abrasive slurry. USM offers a solution to the expanding need for machining brittle materials such as single crystals, glasses and polycrystalline ceramics, and increasing complex operations to provide intricate shapes and workpiece profiles. It is therefore used extensively in machining hard and brittle materials that are difficult to machine by traditional manufacturing processes. The hard particles in slurry are accelerated toward the surface of the workpiece by a tool oscillating at a frequency up to 100 KHz - through repeated abrasions, the tool machines a cavity of a cross section identical to its own. A schematic representation of USM is shown in Figure 1.

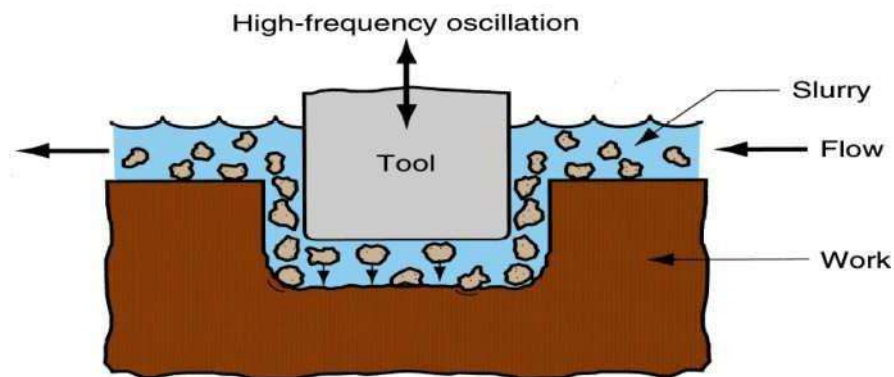

Figure 1: Schematic of ultrasonic machine tool

ADVANCE MANUFACTURING PROCESSES

USM is primarily targeted for the machining of hard and brittle materials (dielectric or conductive) such as boron carbide, ceramics, titanium carbides, rubies, quartz etc. USM is a versatile machining process as far as properties of materials are concerned. This process is able to effectively machine all materials whether they are electrically conductive or insulator.

For an effective cutting operation, the following parameters need to be carefully considered:

- The machining tool must be selected to be highly wear resistant, such as high-carbon steels.
- The abrasives (25-60 μ m in dia.) in the (water-based, up to 40% solid volume) slurry includes: Boron carbide, silicon carbide and aluminumoxide.

Mechanisms of Material Removal in USM and its modeling

As has been mentioned earlier, USM is generally used for machining brittle work material. Material removal primarily occurs due to the indentation of the hard abrasive grits on the brittle work material. As the tool vibrates, it leads to indentation of the abrasive grits. During indentation, due to Hertzian contact stresses, cracks would develop just below the contact site, then as indentation progresses the cracks would propagate due to increase in stress and ultimately lead to brittle fracture of the work material under each individual interaction site between the abrasive grits and the workpiece. The tool material should be such that indentation by the abrasive grits does not lead to brittle failure. Thus the tools are made of tough, strong and ductile materials like steel, stainless steel and other ductile metallic alloys. Other than this brittle failure of the work material due

ADVANCE MANUFACTURING PROCESSES

to indentation some material removal may occur due to free flowing impact of the abrasives against the work material and related solid-solid impact erosion, but it is estimated to be rather insignificant. Thus, in the current model, material removal would be assumed to take place only due to impact of abrasives between tool and workpiece, followed by indentation and brittle fracture of the workpiece. The model does consider the deformation of the tool. In the current model, all the abrasives are considered to be identical in shape and size. An abrasive particle is considered to be spherical but with local spherical bulges as shown in Fig.

9.2.2. The abrasive particles are characterised by the average grit diameter, d_g . It is further assumed that the local spherical bulges have a uniform diameter, d_b and which is related to the grit diameter by $d_b = \mu d_g^2$. Thus an abrasive is characterised by μ and d_g .

Schematic representation of abrasive grit

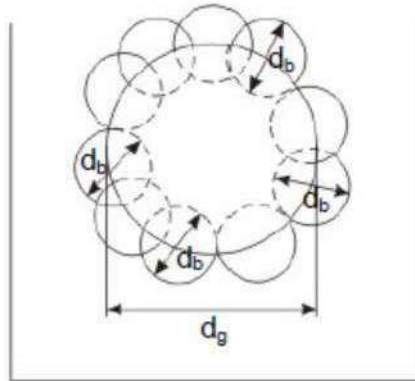

During indentation by the abrasive grit onto the workpiece and the tool, the local spherical bulges contact the surfaces and the indentation process is characterised by d_b rather than by d_g . Fig. 9.2.3 shows the interaction between the abrasive grit and the workpiece and tool.

ADVANCE MANUFACTURING PROCESSES

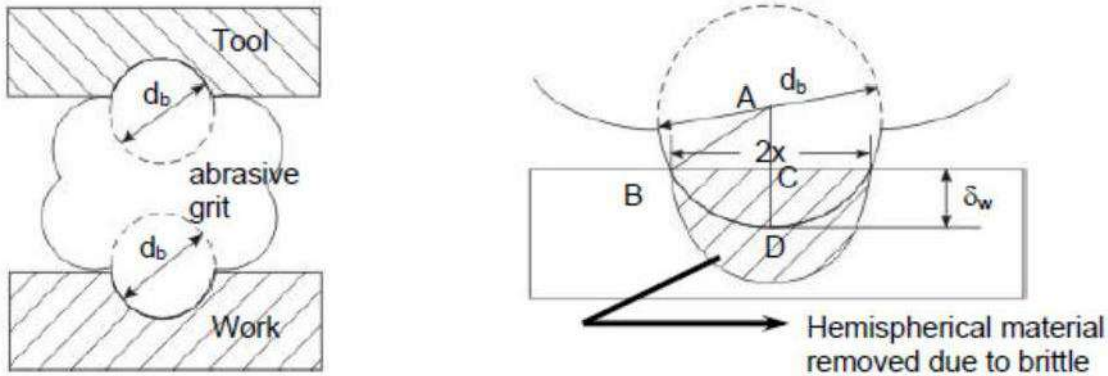

Interaction between grit and workpiece and tool

As the indentation proceeds, the contact zone between the abrasive grit and workpiece is established and the same grows. The contact zone is circular in nature and is characterised by its diameter '2x'. At full indentation, the indentation depth in the work material is characterised by δ_w . Due to the indentation, as the work material is brittle, brittle fracture takes place leading to hemi-spherical fracture of diameter '2x' under the contact zone. Therefore material removal per abrasive grit is given as

$$\Gamma_w = \frac{2}{3} \pi x^3$$

Now from Fig. 9.2.3 $AB^2 = AC^2 + BC^2$

$$\left(\frac{d_b}{2}\right)^2 = \left(\frac{d_b}{2} - \delta_w\right)^2 + x^2$$

$$x^2 = d_b \delta_w \text{ neglecting } \delta_w^2 \text{ as } \delta_w \ll d_b$$

$$\therefore \Gamma_w = \frac{2}{3} \pi (d_b \delta_w)^{3/2}$$

If at any moment of time, there are an average 'n' of grits and the tool is vibrating at a frequency 'f' then material removal rate can be expressed as

$$\begin{aligned} MRR_w &= \Gamma_w . n . f \\ &= \frac{2}{3} \pi (\delta_w d_b)^{3/2} n f \end{aligned}$$

Now as the tool and workpiece would be pressing against each other, contact being established via the abrasive grit, both of them would deform or wear out. As the tool vibrates, for sometime, it vibrates freely; then it comes in contact with the abrasive, which is already in contact with the job.

And then the indentation process starts and finally completes with an indentation of δ_w and δ_t on the work and tool respectively.

ADVANCE MANUFACTURING PROCESSES

The tool vibrates in a harmonic motion. Thus only during its first quarter of its cycle it can derive an abrasive towards interaction with the tool and workpiece as shown in Fig. below. Out of this quarter cycle, some part is used to engage the tool with abrasive particle as shown in Fig. below. Thus the time of indentation τ can be roughly estimated as

$$\frac{\delta}{a_0} = \frac{\tau}{T/4} \Rightarrow \tau = \frac{T\delta}{4a_0} = \frac{T(\delta_w + \delta_t)}{4a_0}$$

Now during machining, the impulse of force on the tool and work would be balanced. Thus total impulse on the tool can be expressed as

$$I_t = n.f. \cdot \frac{1}{2} F_{\max} \tau$$

where F_{\max} is the maximum indentation force per abrasive.

Now in the USM, the tool is fed with an average force F

$$\text{Thus } F = \frac{1}{2} F_{\max} \tau \cdot n.f$$

Again, if the flow strength of work material is taken as σ_w , then

$$\begin{aligned} F_{\max} &= \sigma_w \pi x^2 \\ \therefore F &= \frac{1}{2} \sigma_w \pi x^2 \tau n.f \\ F &= \frac{1}{2} n.f \sigma_w \pi x^2 \frac{T(\delta_w + \delta_t)}{4a_0} \end{aligned}$$

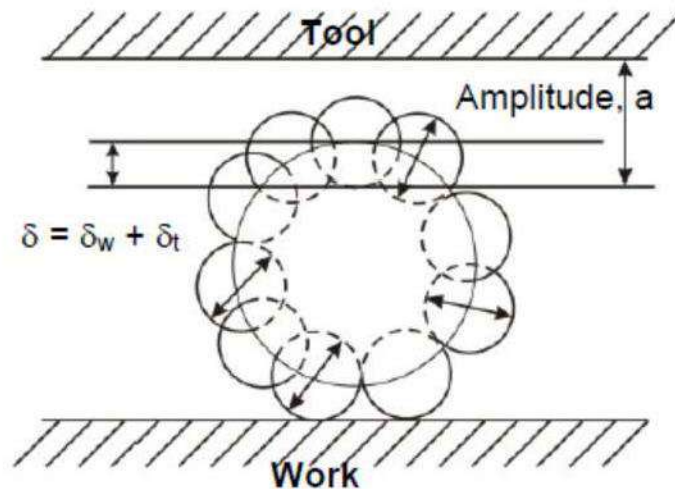

Interaction between grit and workpiece and tool to depict the workpiece and tool deformations

ADVANCE MANUFACTURING PROCESSES

If 'A' is total surface area of the tool facing the workpiece, then volume of abrasive slurry of one grit thickness is

$$Ad_g$$

If n is the number of grits then the total volume of n grits is

$$\frac{\pi d_g^3}{6} n$$

Thus the concentration of abrasive grits in the slurry is related as follows:

$$n \frac{\pi d_g^3}{6} = Ad_g C$$

$$C = \frac{\frac{\pi d_g^3}{6} n}{Ad_g} = \frac{\pi d_g^2}{6A} n$$

$$\therefore n = \frac{6AC}{\pi d_g^2}$$

Now it is expected that indentation would be inversely proportional to the flow strength then,

$$\frac{\delta_t}{\delta_w} = \frac{\sigma_w}{\sigma_t} = \lambda$$

Again combining, 'F' can be written as

$$F = \frac{1}{2} n f \sigma_w \pi \chi^2 \frac{T}{4a_o} \delta_w (1 + \lambda)$$

$$F = \frac{1}{2} \frac{6AC}{\pi d_g^2} \cdot f \cdot \sigma_w \cdot \pi d_b \delta_w \frac{T}{4a_o} \delta_w (1 + \lambda)$$

$$F = \frac{3AC}{d_g^2} \cdot (fT) \cdot \frac{\sigma_w}{4a_o} d_b \delta_w^2 (1 + \lambda)$$

$$F = \frac{3AC}{d_g^2} (fT) \cdot \frac{\sigma_w}{4a_o} \mu d_g^2 \delta_w^2 (1 + \lambda)$$

$$\delta_w^2 = \frac{4a_o F}{3\mu AC \sigma_w (1 + \lambda)}$$

ADVANCE MANUFACTURING PROCESSES

Now,

$$\begin{aligned}
 MRR &= \Gamma_w n f \\
 &= \frac{2}{3} \pi x^3 n f \\
 &= \frac{2}{3} \pi \frac{6cA}{\pi d_g^2} f \cdot x^3 \\
 &= 4\pi \frac{cA}{\pi d_g^2} f \cdot (d_b \delta_w)^{3/2} = \frac{4cA}{d_g^2} f \cdot (\mu d_g^2 \delta_w)^{3/2} \\
 &= 4cA d_g \mu^{3/2} f \cdot \left\{ \frac{4Fa_0}{3\mu A c \sigma_w (1+\lambda)} \right\}^{3/4}
 \end{aligned}$$

$$\begin{aligned}
 MRR &\propto \frac{c^{1/4} A^{1/4} F^{3/4} a_0^{3/4} d_g f}{\sigma_w^{3/4} (1+\lambda)^{3/4}} \mu^{3/4} \\
 &\propto d_g f \frac{c^{1/4} A p^{3/4} a_0^{3/4}}{\sigma_w^{3/4} (1+\lambda)^{3/4}} \mu^{3/4}
 \end{aligned}$$

Process Parameters and their effects:

During discussion and analysis as presented in the previous section, the process parameters which govern the ultrasonic machining process have been identified and the same are listed below along with material parameters

- Amplitude of vibration (a_0) – 15 – 50 μm
- Frequency of vibration (f) – 19 – 25 kHz
- Feed force (F) – related to tool dimensions
- Feed pressure (p)
- Abrasive size – 15 μm – 150 μm
- Abrasive material – Al_2O_3
 - SiC
 - B_4C
 - Boronsilicarbide
 - Diamond
- Flow strength of work material
- Flow strength of the tool material
- Contact area of the tool – A
- Volume concentration of abrasive in water slurry – C

ADVANCE MANUFACTURING PROCESSES

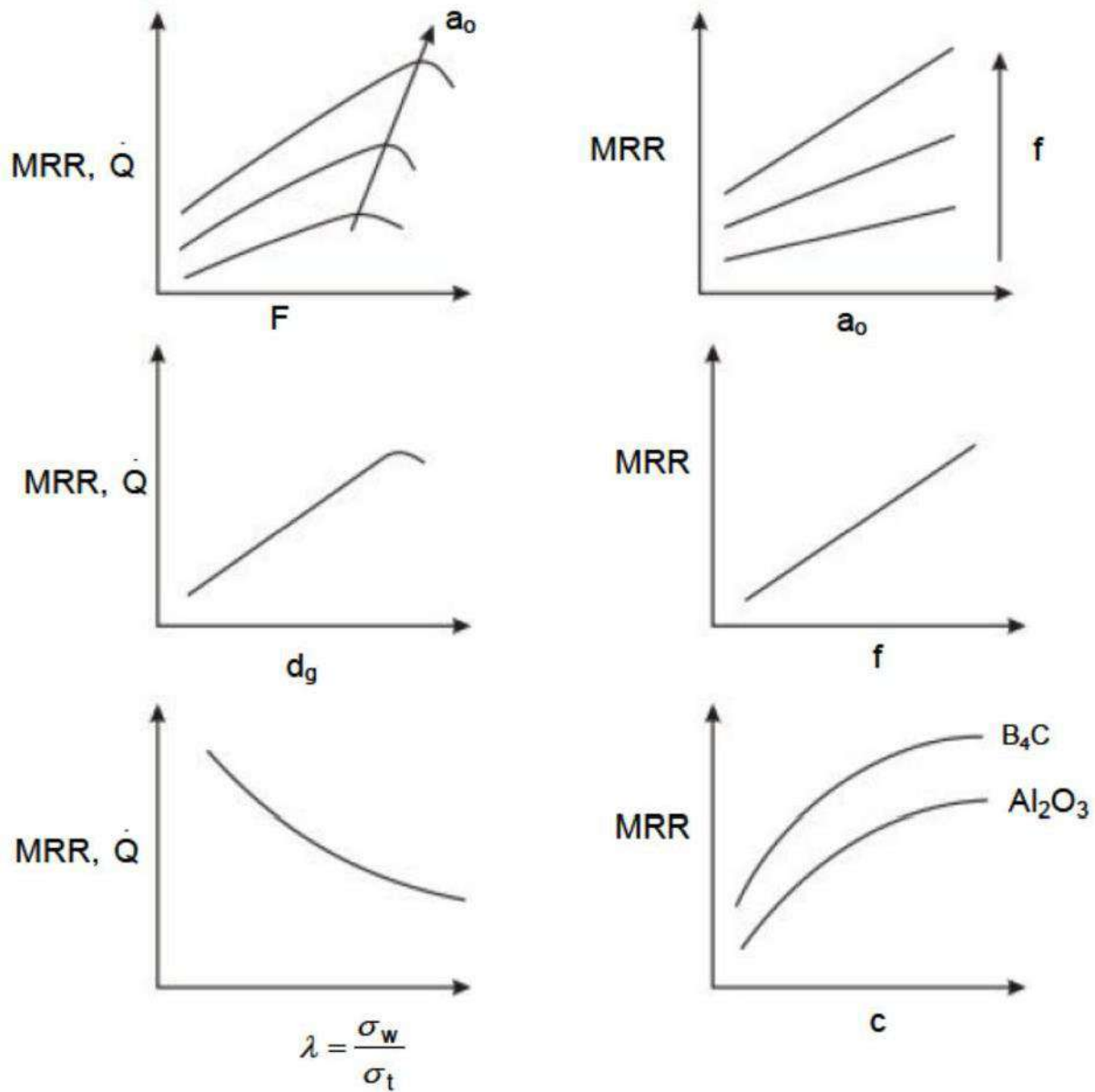

Effect of machining parameters on MRR

Equipment:

The basic mechanical structure of an USM is very similar to a drill press. However, it has additional features to carry out USM of brittle work material. The workpiece is mounted on a vice, which can be located at the desired position under the tool using a 2 axis table. The table can further be

ADVANCE MANUFACTURING PROCESSES

lowered or raised to accommodate work of different thickness. The typical elements of an USM are (Fig.)

- Slurry delivery and return system
- Feed mechanism to provide a downward feed force on the tool during machining
- The transducer, which generates the ultrasonic vibration Version 2ME, IIT Kharagpur
- The horn or concentrator, which mechanically amplifies the vibration to the required amplitude of 15 – 50 μm and accommodates the tool at its tip.

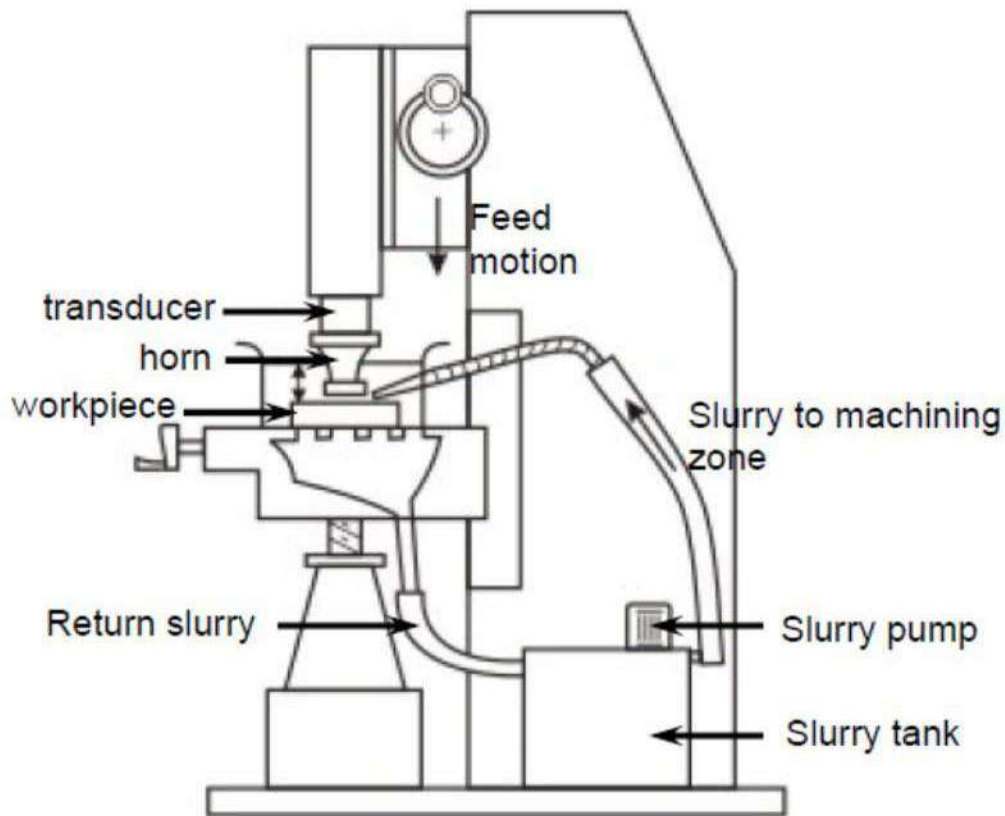

Schematic view of an Ultrasonic Machine

The ultrasonic vibrations are produced by the transducer. The transducer is driven by suitable signal generator followed by power amplifier. The transducer for USM works on the following principle

ADVANCE MANUFACTURING PROCESSES

- Piezoelectric effect
- Magnetostrictive effect
- Electrostrictive effect Magnetostrictive transducers are most popular and robust amongst all.

Fig. below shows a typical magnetostrictive transducer along with horn. The horn or concentrator is a wave-guide, which amplifies and concentrates the vibration to the tool from the transducer.

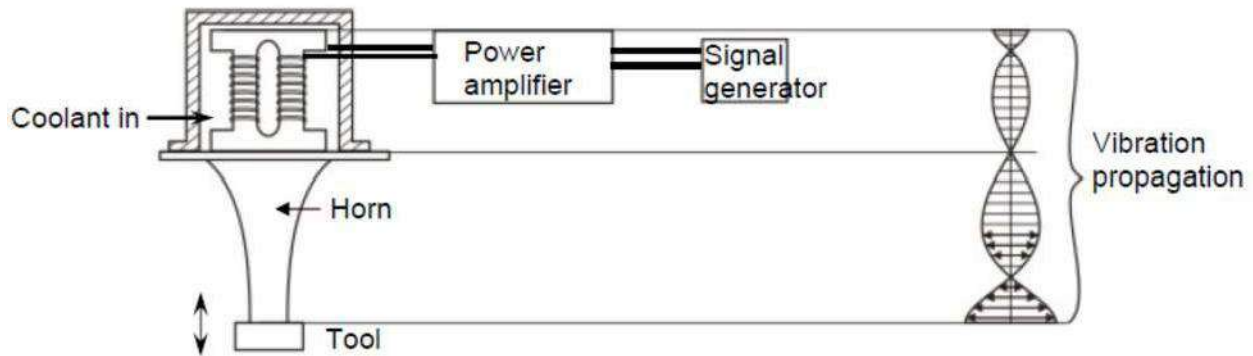

Working of horn as mechanical amplifier of amplitude of vibration

The horn or concentrator can be of different shape like

- Tapered or conical
- Exponential
- Stepped

Machining of tapered or stepped horn is much easier as compared to the exponential one. Fig. 9.2.9 shows different horns used in USM

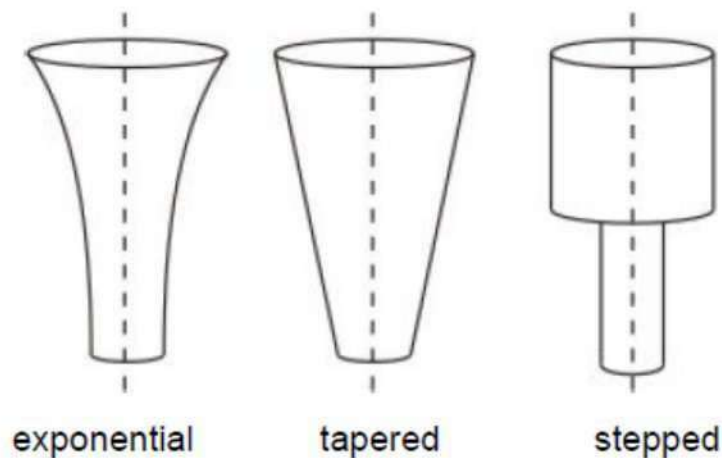

ADVANCE MANUFACTURING PROCESSES

Different Horns used in USM

Applications

The beauty of USM is that it can make non round shapes in hard and brittle materials. Ultrasonically machined non round-hole part is shown in Figure2.

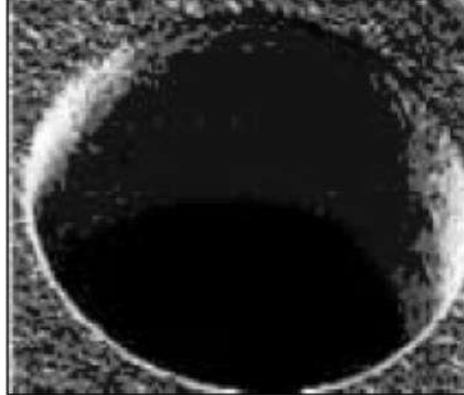

Figure 2: A non-round hole made by USM

Advantage of USM

USM process is a non-thermal, non-chemical, creates no changes in the microstructures, chemical or physical properties of the workpiece and offers virtually stress free machined surfaces.

- Any materials can be machined regardless of their electrical conductivity
- Especially suitable for machining of brittle materials
- Machined parts by USM possess better surface finish and higher structural integrity.
- USM does not produce thermal, electrical and chemical abnormal surface

Some disadvantages of USM

ADVANCE MANUFACTURING PROCESSES

- USM has higher power consumption and lower material-removal rates than traditional fabrication processes.
- Tool wears fast in USM.
- Machining area and depth is restraint in USM.

Water Jet Machining

Water jet machining can reduce the costs and speed up the processes by eliminating or reducing expensive secondary machining process. Since no heat is applied on the materials, cut edges are clean with minimal burr. Problems such as cracked edge defects, crystallization, hardening, reduced weldability and machinability are reduced in this process.

Water jet technology uses the principle of pressurizing water to extremely high pressures, and allowing the water to escape through a very small opening called “orifice” or “jewel”. Water jet cutting uses the beam of water exiting the orifice to cut soft materials. This method is not suitable for cutting hard materials. The inlet water is typically pressurised between 1300 – 4000 bars. This high pressure is forced through a tiny hole in the jewel, which is typically 0.18 to 0.4 mm in diameter. A picture of water jet machining process is shown in Figure 3.

ADVANCE MANUFACTURING PROCESSES

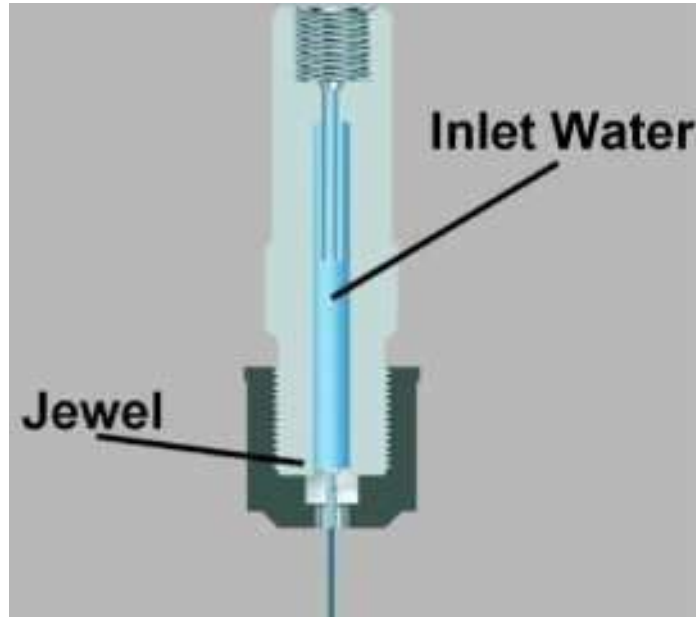

Figure 3: Water jet cutting
(http://www.waterjets.org/about_abrasivejets.html)

Applications

Water jet cutting is mostly used to cut lower strength materials such as wood, plastics and aluminium. When abrasives are added, (abrasive water jet cutting) stronger materials such as steel and tool steel can be cut.

Advantages of water jet cutting

- There is no heat generated in water jet cutting; which is especially useful for cutting tool steel and other metals where excessive heat may change the properties of the material.
- Unlike machining or grinding, water jet cutting does not produce any dust or particles that are harmful if inhaled.
- Other advantages are similar to abrasive water jet cutting

Disadvantages of water jet cutting

ADVANCE MANUFACTURING PROCESSES

- One of the main disadvantages of water jet cutting is that a limited number of materials can be cut economically.
- Thick parts cannot be cut by this process economically and accurately
- Taper is also a problem with water jet cutting in very thick materials. Taper is when the jet exits the part at different angle than it enters the part, and cause dimensional inaccuracy.

Abrasive Jet Machining

ABRASIVE JET MACHINING (AJM): Introduction, Equipment, Variables in AJM: Carrier Gas, Type of abrasive work material, stand off distance (SOD), nozzle design, shape of cut. Process characteristics-Material removal rate, Nozzle wear, Accuracy & surface finish. Applications, advantages & Disadvantages of AJM.

Abrasive jet machining is an extended version of water jet cutting; in which the water jet contains abrasive particles such as silicon carbide or aluminum oxide in order to increase the material removal rate above that of water jet machining. Almost any type of material ranging from hard brittle materials such as ceramics, metals and glass to extremely soft materials such as foam and rubbers can be cut by abrasive water jet cutting. The narrow cutting stream and computer controlled movement enables this process to produce parts accurately and efficiently. This machining process is especially ideal for cutting materials that cannot be cut by laser or thermal cut. Metallic, non-metallic and advanced composite materials of various thicknesses can be cut by this process. This process is particularly suitable for heat sensitive materials that cannot be machined by processes that produce heat while machining.

The schematic of abrasive water jet cutting is shown in Figure 15 which is similar to water jet cutting apart from some more features underneath the jewel; namely abrasive, guard and mixing tube. In this process, high

ADVANCE MANUFACTURING PROCESSES

velocity water exiting the jewel creates a vacuum which sucks abrasive from the abrasive line, which mixes with the water in the mixing tube to form a high velocity beam of abrasives.

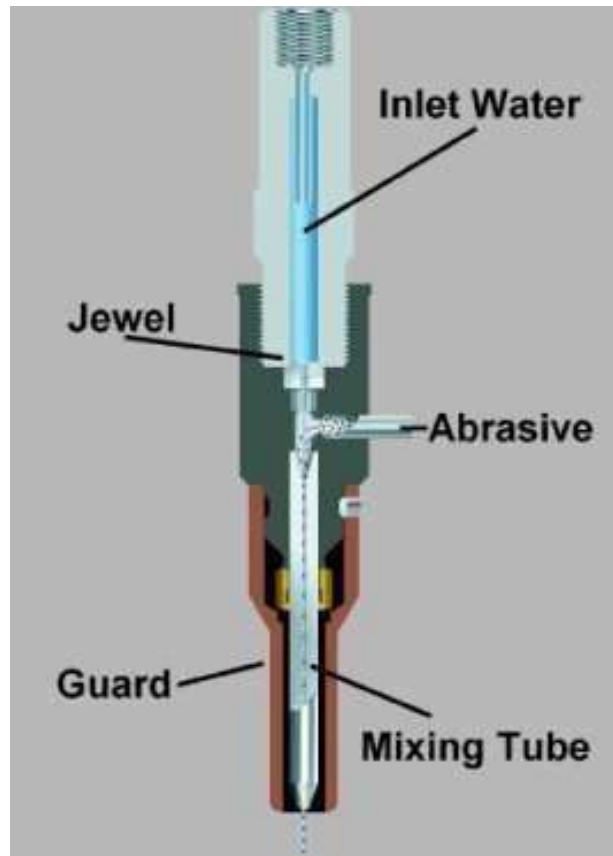

Figure 4: Abrasive water jet machining
(http://www.waterjets.org/about_abrasivejets.html)

Applications

Abrasive water jet cutting is highly used in aerospace, automotive and electronics industries. In aerospace industries, parts such as titanium bodies for military aircrafts, engine components (aluminum, titanium, heat resistant alloys), aluminum body parts and interior cabin parts are made using abrasive water jet cutting.

ADVANCE MANUFACTURING PROCESSES

In automotive industries, parts like interior trim (head liners, trunk liners, door panels) and fibre glass body components and bumpers are made by this process. Similarly, in electronics industries, circuit boards and cable stripping are made by abrasive water jet cutting.

Advantages of abrasive water jet cutting

- In most of the cases, no secondary finishing required
- No cutter induced distortion
- Low cutting forces on work pieces
- Limited tooling requirements
- Little to no cutting burr
- Typical finish 125-250 microns
- Smaller kerf size reduces material wastages
- No heat affected zone
- Localizes structural changes
- No cutter induced metal contamination
- Eliminates thermal distortion
- No slag or cutting dross
- Precise, multi plane cutting of contours, shapes, and bevels of any angle.

Limitations of abrasive water jet cutting

- Cannot drill flat bottom
- Cannot cut materials that degrades quickly with moisture
- Surface finish degrades at higher cut speeds which are frequently used for rough cutting.
- The major disadvantages of abrasive water jet cutting are high capital cost and high noise levels during operation.

ADVANCE MANUFACTURING PROCESSES

A component cut by abrasive water jet cutting is shown in Figure 5. As it can be seen, large parts can but cut with very narrow kerf which reduces material wastages. The complex shape part made by abrasive water jet cutting is shown in Figure 6.



Figure 5: Abrasive water jet cutting



Figure 6: Steel gear and rack cut with an abrasive water jet

ADVANCE MANUFACTURING PROCESSES

Module-II

Electrochemical Machining (ECM)

Electrochemical machining (ECM) is a metal-removal process based on the principle of reverse electroplating. In this process, particles travel from the anodic material (workpiece) toward the cathodic material (machining tool). A current of electrolyte fluid carries away the depleted material before it has a chance to reach the machining tool. The cavity produced is the female mating image of the tool shape.

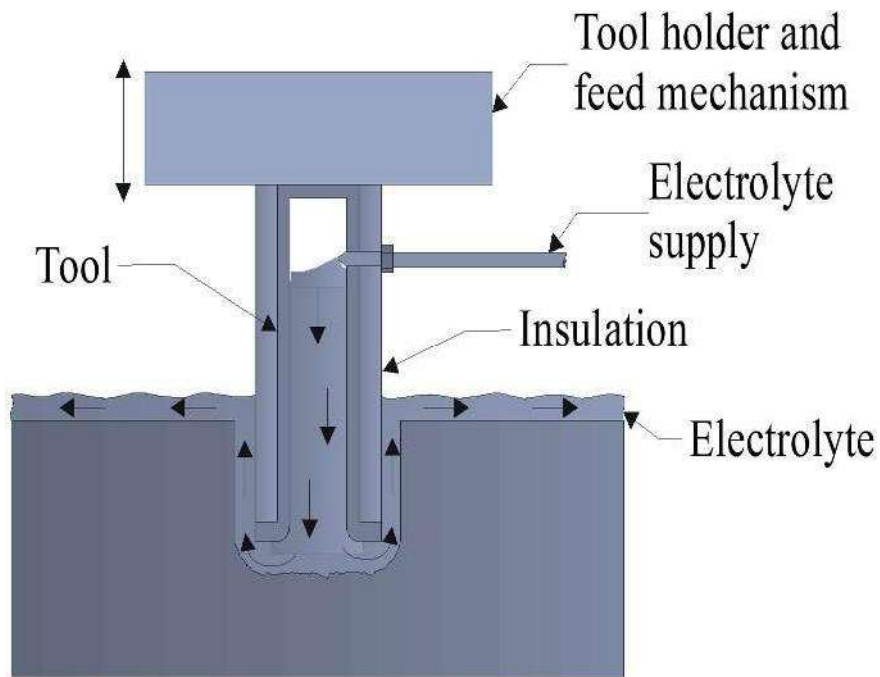

Figure7: ECM process

Similar to EDM, the work piece hardness is not a factor, making ECM suitable for machining difficult-to-machine materials. Difficult shapes can be made by this process on materials regardless of their hardness. A schematic representation of ECM process is shown in Figure 8. The ECM tool is positioned very close to the workpiece and a low voltage, high

ADVANCE MANUFACTURING PROCESSES

amperage DC current is passed between the workpiece and electrode. Some of the shapes made by ECM process is shown in Figure 8.



Figure 9: Parts made by ECM

Equipment used in ECM:

The electrochemical machining system has the following modules:

- Power supply
- Electrolyte filtration and delivery system
- Tool feed system
- Working tank

Fig. 4 schematically shows an electrochemical drilling unit.

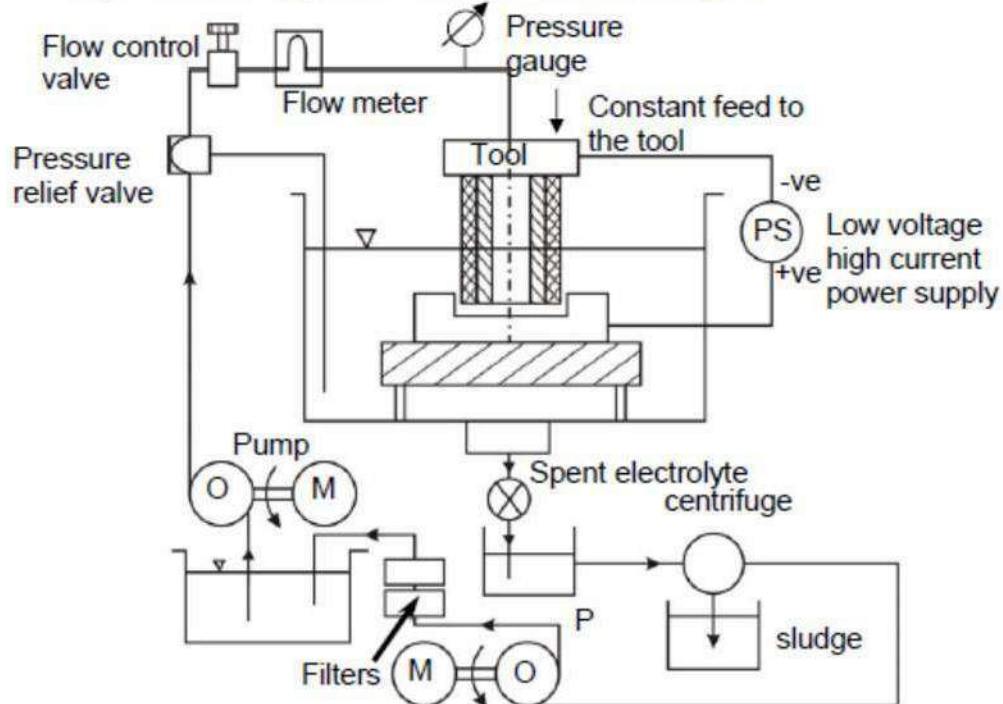

Schematic diagram of a electro chemical drilling unit

ADVANCE MANUFACTURING PROCESSES

Material Removal in ECM:

Material removal rate (MRR) is an important characteristic to evaluate efficiency of a non-traditional machining process.

In ECM, material removal takes place due to atomic dissolution of work material. Electrochemical dissolution is governed by Faraday's laws.

The first law states that the amount of electrochemical dissolution or deposition is proportional to amount of charge passed through the electrochemical cell, which may be expressed as:

$$m \propto Q,$$

where m = mass of material dissolved or deposited

Q = amount of charge passed

The second law states that the amount of material deposited or dissolved further depends on Electrochemical Equivalence (ECE) of the material that is again the ratio of the atomic weight and valency. Thus

$$m \propto ECE \propto \frac{A}{v}$$

$$\text{Thus } m \propto \frac{QA}{Fv}$$

where F = Faraday's constant
= 96500 coulombs

$$\therefore m = \frac{ItA}{Fv}$$

$$\therefore \text{MRR} = \frac{m}{t\rho} = \frac{IA}{F\rho v}$$

where I = current

ρ = density of the material

The engineering materials are quite often alloys rather than element consisting of different elements in a given proportion.

Let us assume there are 'n' elements in an alloy. The atomic weights are given as A_1, A_2, \dots, A_n with valency during electrochemical dissolution as v_1, v_2, \dots, v_n . The weight percentages of different elements are $\alpha_1, \alpha_2, \dots, \alpha_n$ (in decimal fraction)

Now for passing a current of I for a time t , the mass of material dissolved for any element 'i' is given by

$$m_i = \Gamma_a \rho \alpha_i$$

where Γ_a is the total volume of alloy dissolved. Each element present in the alloy takes a certain amount of charge to dissolve.

$$m_i = \frac{Q_i A_i}{F v_i}$$

$$\Rightarrow Q_i = \frac{F m_i v_i}{A_i}$$

$$\Rightarrow Q_i = \frac{F \Gamma_a \rho \alpha_i v_i}{A_i}$$

The total charge passed

ADVANCE MANUFACTURING PROCESSES

Now

$$Q_T = It = \sum Q_i$$
$$\therefore Q_T = It = F \Gamma_a \rho \sum \frac{\alpha_i v_i}{A_i}$$

$$MRR = \frac{\Gamma_a}{t} = \frac{1}{F \rho} \cdot \frac{I}{\sum \frac{\alpha_i v_i}{A_i}}$$

Dynamics of Electro chemical Machining:

ADVANCE MANUFACTURING PROCESSES

ECM can be undertaken without any feed to the tool or with a feed to the tool so that a steady machining gap is maintained. Let us first analyse the dynamics with NO FEED to the tool. Fig. 5 schematically shows the machining (ECM) with no feed to the tool and an instantaneous gap between the tool and workpiece of 'h'.

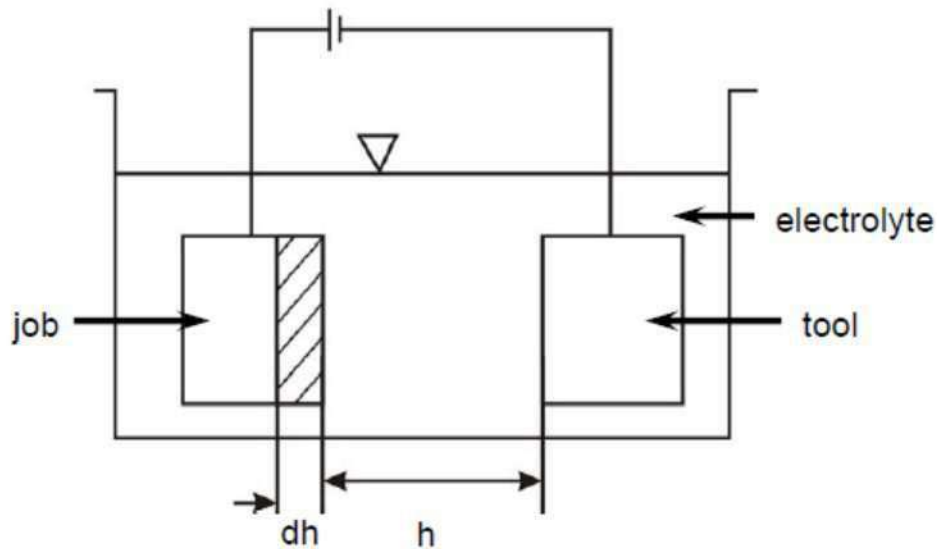

Fig. 5 Schematic representation of the ECM process with no feed to the tool

Now over a small time period 'dt' a current of I is passed through the electrolyte and that leads to an electrochemical dissolution of the material of amount 'dh' over an area of S

$$\therefore I = \frac{V}{R} = \frac{V}{\frac{rh}{s}} = \frac{Vs}{rh}$$

$$\text{then } \frac{dh}{dt} = \frac{1}{F} \cdot \frac{A_x}{\rho v_x} \left(\frac{Vs}{rh} \cdot \frac{1}{s} \right)$$

$$= \frac{1}{F} \cdot \frac{A_x}{\rho v_x} \cdot \frac{V}{rh}$$

for a given potential difference and alloy

ADVANCE MANUFACTURING PROCESSES

$$\frac{dh}{dt} = \frac{A_x V}{F \rho v_x r} \cdot \frac{1}{h} = \frac{c}{h}$$

where $c = \text{constant}$

$$= \frac{A_x V}{F \rho v_x r}$$
$$c = \frac{V}{F \rho r \sum \frac{\alpha_i v_i}{A_i}}$$

$$\therefore \frac{dh}{dt} = \frac{c}{h}$$

$$h dh = c dt$$

At $t = 0$, $h = h_0$ and at $t = t_1$ and $h = h_1$

$$\therefore \int_{h_0}^{h_1} h dh = c \int_0^t dt$$

$$\therefore h_1^2 - h_0^2 = 2ct$$

ADVANCE MANUFACTURING PROCESSES

That is the tool – workpiece gap under zero feed condition grows gradually following a parabolic curve as shown in Fig. 6

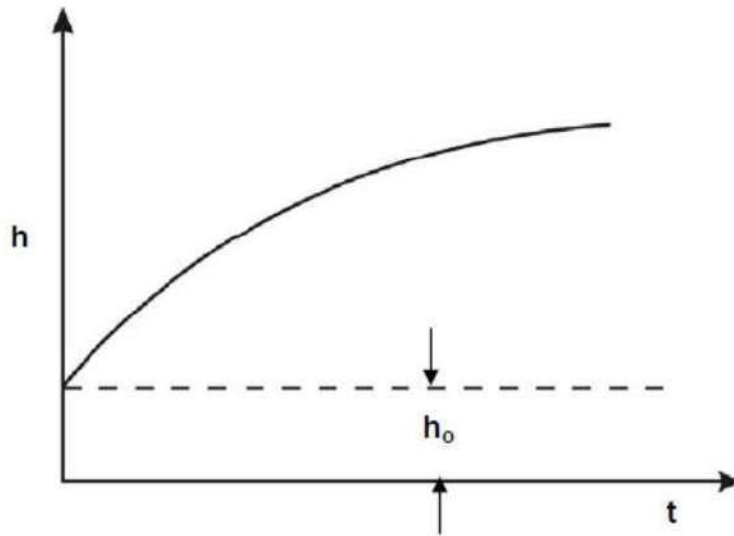

Fig. 6 Variation of tool-workpiece gap under zero feed condition

As
$$\frac{dh}{dt} = \frac{c}{h}$$

Thus dissolution would gradually decrease with increase in gap as the potential drop across the electrolyte would increase

ADVANCE MANUFACTURING PROCESSES

Now generally in ECM a feed (f) is given to the tool

$$\therefore \frac{dh}{dt} = \frac{c}{h} - f$$

Now if the feed rate is high as compared to rate of dissolution, then after : the gap would diminish and may even lead to short circuiting. Under steady condition the gap is uniform i.e. the approach of the tool is compensated by the dissolution of the work material. Thus with respect to the tool, the workpiece is moving

$$\text{Thus } \frac{dh}{dt} = 0 = \frac{c}{h} - f$$

$$\therefore f = \frac{c}{h}$$

or $h^* = \text{steady state gap} = c/f$

Now under practical ECM condition it is not possible to set exactly the value of the initial gap. Thus it is required to be analysed if the initial gap value will have any effect on progress of the process

$$\text{Now } \frac{dh}{dt} = \frac{c}{h} - f$$

$$\text{Now } h' = \frac{h}{h^*} = \frac{hf}{c}$$

$$\text{And } t' = \frac{ft}{h^*} = \frac{f^2 t}{c}$$

$$\therefore \frac{dh'}{dt'} = \frac{f/c}{f^2/c} \cdot \frac{dh}{dt} = \frac{1}{f} \cdot \frac{dh}{dt}$$

$$\text{Thus } \frac{dh}{dt} = \frac{c}{h} - f$$

$$\Rightarrow f \frac{dh'}{dt'} = \frac{c}{h'h^*} - f = \frac{cf}{h'c} - f$$

$$\Rightarrow f \frac{dh'}{dt'} = f \left(\frac{1-h'}{h'} \right)$$

$$\Rightarrow \frac{dh'}{dt'} = \frac{1-h'}{h'}$$

$$\therefore dt' = \frac{h'}{1-h'} dh'$$

Now integrating between $t' = 0$ to $t' = t'$ when h' changes from h_0' to h_1'

$$\therefore \int_0^{t'} dt' = \int_{h_0'}^{h_1'} \frac{h'}{1-h'} dh'$$

$$\therefore t' = \int_{h_0'}^{h_1'} -\frac{d(1-h')}{(1-h')} + \int_{h_0'}^{h_1'} d(1-h')$$

$$t' = h_0' - h_1' + \ln \frac{h_0' - 1}{h_1' - 1}$$

now for different value of h_0' , h_1' seems to approach 1 as shown in Fig. 7

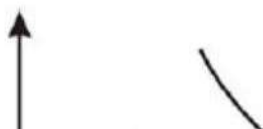

ADVANCE MANUFACTURING PROCESSES

ADVANCE MANUFACTURING PROCESS

Advantages of ECM

- The components are not subject to either thermal or mechanical stress.
- No tool wear during ECM process.
- Fragile parts can be machined easily as there is no stress involved.
- ECM deburring can debur difficult to access areas of parts.
- High surface finish (up to 25 μm in) can be achieved by ECM process.
- Complex geometrical shapes in high-strength materials particularly in the aerospace industry for the mass production of turbine blades, jet-engine parts and nozzles can be machined repeatedly and accurately.
- Deep holes can be made by this process.

Limitations of ECM

- ECM is not suitable to produce sharp square corners or flat bottoms because of the tendency for the electrolyte to erode away sharp profiles.
- ECM can be applied to most metals but, due to the high equipment costs, is usually used primarily for highly specialized applications.

Material removal rate, MRR, in electrochemical machining:

$$\text{MRR} = C \cdot I \cdot h (\text{cm}^3/\text{min})$$

C: specific (material) removal rate (e.g., 0.2052 $\text{cm}^3/\text{amp-min}$ for nickel);

I: current (amp);

h: current efficiency (90–100%).

ADVANCE MANUFACTURING PROCESS

The rates at which metal can electrochemically remove are in proportion to the current passed through the electrolyte and the elapsed time for that operation. Many factors other than current influence the rate of machining. These involve electrolyte type, rate of electrolyte flow, and some other process conditions.

Chemical Machining (CM)

Chemical machining (CM) is the controlled dissolution of workpiece material (etching) by means of a strong chemical reagent (etchant). In CM material is removed from selected areas of workpiece by immersing it in a chemical reagents or etchants; such as acids and alkaline solutions. Material is removed by microscopic electrochemical cell action, as occurs in corrosion or chemical dissolution of a metal. This controlled chemical dissolution will simultaneously etch all exposed surfaces even though the penetration rates of the material removal may be only 0.0025–0.1 mm/min. The basic process takes many forms: chemical milling of pockets, contours, overall metal removal, chemical blanking for etching through thin sheets; photochemical machining (pcm) for etching by using of photosensitive resists in microelectronics; chemical or electrochemical polishing where weak chemical reagents are used (sometimes with remote electric assist) for polishing or deburring and chemical jet machining where a single chemically active jet is used. A schematic of chemical machining process is shown in Figure 10.

ADVANCE MANUFACTURING PROCESS

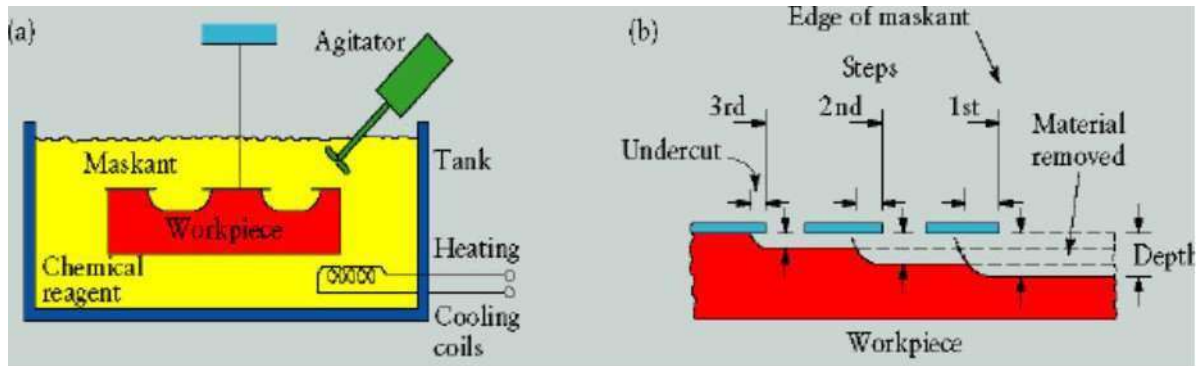

Figure 10: (a) Schematic of chemical machining process (b) Stages in producing a profiled cavity by chemical machining (Kalpakjain&Schmid)

Chemical milling

In chemical milling, shallow cavities are produced on plates, sheets, forgings and extrusions. The two key materials used in chemical milling process are etchant and maskant. Etchants are acid or alkaline solutions maintained within controlled ranges of chemical composition and temperature. Maskants are specially designed elastomeric products that are hand strippable and chemically resistant to the harsh etchants.

Steps in chemical milling

- Residual stress relieving: If the part to be machined has residual stresses from the previous processing, these stresses first should be relieved in order to prevent warping after chemical milling.
- Preparing: The surfaces are degreased and cleaned thoroughly to ensure both good adhesion of the masking material and the uniform material removal.
- Masking: Masking material is applied (coating or protecting areas not to be etched).
- Etching: The exposed surfaces are machined chemically with etchants.
- Demasking: After machining, the parts should be washed thoroughly to prevent further reactions with or exposure to any etchant residues.

ADVANCE MANUFACTURING PROCESS

Then the rest of the masking material is removed and the part is cleaned and inspected.

Applications:

- Chemical milling is used in the aerospace industry to remove shallow layers of material from large aircraft components missile skin panels (Figure 11), extruded parts for airframes.

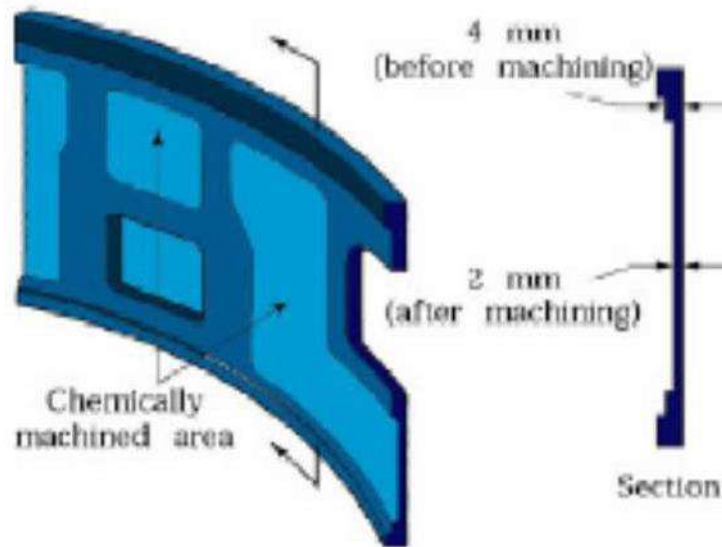

Figure 11: Missile skin-panel section contoured by chemical milling to improve the stiffness- to- weight ratio of the part (Kalpakjain&Schmid)

Electrical Discharge Machining (EDM)

Introduction

Electrical discharge machining (EDM) is one of the most widely used non- traditional machining processes. The main attraction of EDM over traditional machining processes such as metal cutting using different tools and grinding is that this technique utilises thermoelectric process to erode undesired materials from the workpiece by a series of discrete electrical

ADVANCE MANUFACTURING PROCESS

sparks between the workpiece and the electrode. A picture of EDM machine in operation is shown in Figure 12.



Figure 12: Electrical discharge machine

The traditional machining processes rely on harder tool or abrasive material to remove the softer material whereas non-traditional machining processes such as EDM uses electrical spark or thermal energy to erode unwanted material in order to create desired shape. So, the hardness of the material is no longer a dominating factor for EDM process. A schematic of an EDM process is shown in Figure 13, where the tool and the workpiece are immersed in a dielectric fluid.

ADVANCE MANUFACTURING PROCESS

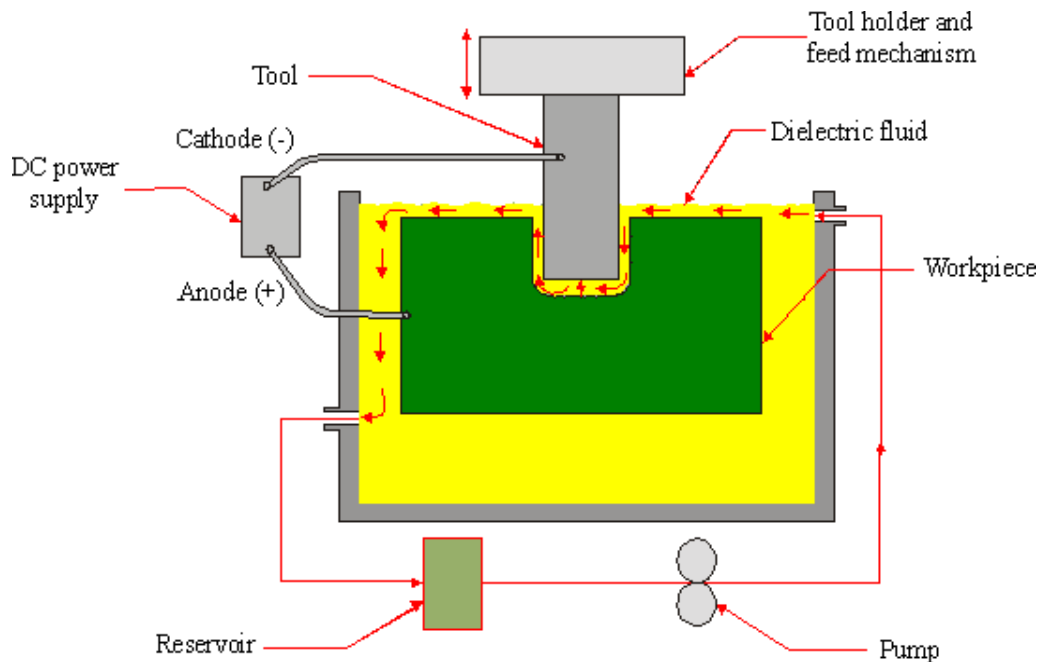

Figure 13: Schematic of EDM process

EDM removes material by discharging an electrical current, normally stored in a capacitor bank, across a small gap between the tool (cathode) and the workpiece (anode) typically in the order of 50 volts/10amps.

EDM – Components

The main components in EDM:

- Electric power supply
- Dielectric medium
- Work piece & tool
- Servo control unit.

The work piece and tool are electrically connected to a DC power supply.

The current density in the discharge of the channel is of the order of 10000 A/cm² and power density is nearly 500 MW/cm².

A gap, known as SPARK GAP in the range, from 0.005 mm to 0.05 mm is maintained between the work piece and the tool.

ADVANCE MANUFACTURING PROCESS

Dielectric slurry is forced through this gap at a pressure of 2 kgf/cm² or lesser.

EDM – Working Principle

- It is a process of metal removal based on the principle of material removal by an interrupted electric spark discharge between the electrode tool and the work piece.
- In EDM, a potential difference is applied between the tool and workpiece.
- Essential - Both tool and work material are to be conductors.
- The tool and work material are immersed in a dielectric medium.
- Generally kerosene or deionised water is used as the dielectric medium.
- A gap is maintained between the tool and the workpiece.
- Depending upon the applied potential difference (50 to 450 V) and the gap between the tool and workpiece, an electric field would be established.
- Generally the tool is connected to the negative terminal (cathode) of the generator and the workpiece is connected to positive terminal (anode).
- As the electrons get accelerated, more positive ions and electrons would get generated due to collisions.
- This cyclic process would increase the concentration of electrons and ions in the dielectric medium between the tool and the job at the spark gap.
- The concentration would be so high that the matter existing in that channel could be characterized as "plasma".
- The electrical resistance of such plasma channel would be very less.
- Thus all of a sudden, a large number of electrons will flow from tool to job and ions from job to tool.
- This is called avalanche motion of electrons.
- Such movement of electrons and ions can be visually seen as a spark.
- Thus the electrical energy is dissipated as the thermal energy of the spark.
- The high speed electrons then impinge on the job and ions on the tool.

ADVANCE MANUFACTURING PROCESS

- The kinetic energy of the electrons and ions on impact with the surface of the job and tool respectively would be converted into thermal energy or heat flux.
- Such intense localized heat flux leads to extreme instantaneous confined rise in temperature which would be in excess of 10,000°C.
- Such localized extreme rise in temperature leads to material removal.
- Material removal occurs due to instant vaporization of the material as well as due to melting.
- The molten metal is not removed completely but only partially.

Electrode Material

Electrode material should be such that it would not undergo much tool wear when it is impinged by positive ions. Thus the localized temperature rise has to be less by tailoring or properly choosing its properties or even when temperature increases, there would be less melting. Further, the tool should be easily workable as intricate shaped geometric features are machined in EDM.

Thus the basic characteristics of electrode materials are:

- High electrical conductivity – electrons are cold emitted more easily and there is less bulk electrical heating
- High thermal conductivity
- Higher density
- High melting point – high melting point leads to less tool wear due to less tool material melting for the same heat load
- Easy manufacturability
- Cost – cheap e.g.: Graphite, Electrolytic, oxygen free copper, Tellurium copper – 99% Cu+0.5% tellurium, Brass

Working principle of EDM

As shown in Figure 12, at the beginning of EDM operation, a high voltage is applied across the narrow gap between the electrode and the workpiece. This high voltage induces an electric field in the insulating dielectric that is present in narrow gap between electrode and workpiece. This causes conducting particles suspended in the dielectric to concentrate at the points of strongest electrical field. When the potential difference between the

ADVANCE MANUFACTURING PROCESS

electrode and the workpiece is sufficiently high, the dielectric breaks down and a transient spark discharges through the dielectric fluid, removing small amount of material from the workpiece surface. The volume of the material removed per spark discharge is typically in the range of 10^{-6} to 10^{-6} mm³.

The material removal rate, MRR, in EDM is calculated by the following formula:

$$MRR = 40 I / T_m^{1.23} \quad (cm^3/min)$$

Where, I is the current amp,

T_m is the melting temperature of workpiece in °C

Mechanism of metal removal

Fundamentally, the electro sparking method of metal working involves an electric erosion effect which connotes the breakdown of electrode material accompanying any form of electric discharge. A necessary condition for producing a discharge is the ionization of the dielectric that is splitting up of its molecules into ions and electrons.

Consider the case of a discharge between two electrodes (tool cathode

ADVANCE MANUFACTURING PROCESS

and work anode) through a gaseous (Fig. 4.11) or liquid medium. As soon as suitable voltage is applied across the electrodes, the potential intensity of the electric field between them builds up, until at some predetermined value, the individual electrons break loose from the surface of the cathode and are impelled towards the anode under the influence of field forces (Fig. 4.11). While moving in the inter-electrode space, the electrons collide with the neutral molecules of the dielectric, detaching electrons from them and causing ionization. At some time or the other, the ionization becomes such that a narrow channel of continuous conductivity is formed. When this happens, there is a considerable flow of electrons along the channel to the anode, resulting in a momentary current impulse or discharge. The liberation of energy accompanying the discharge leads to the generation of extremely high temperature, between $8,000^{\circ}$ and $12,000^{\circ}\text{C}$, causing fusion or partial vapourization of the metal and the dielectric fluid at the point of discharge. The metal in the form of liquid drops is dispersed into the space surrounding the electrodes by the explosive pressure of the gaseous products in the discharge. This results in the formation of a tiny crater at the point of discharge in the workpiece.

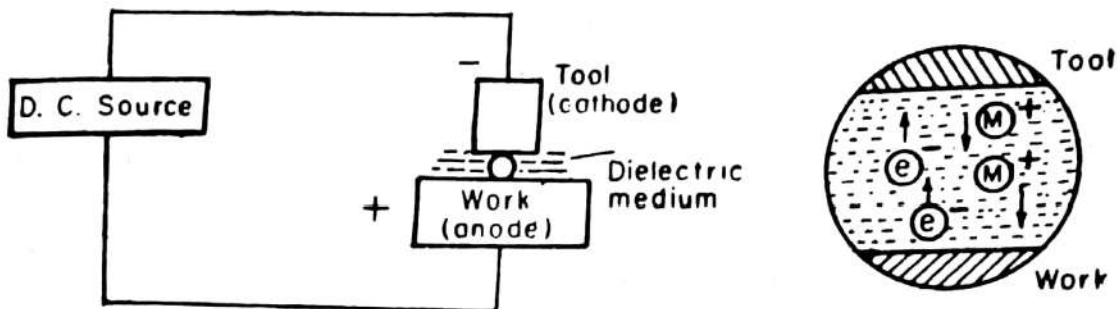

Fig. 4.11

Comparatively less metal is eroded from the cathode (tool) as compared to the anode work due to the following reasons:

- (i) The momentum with which positive ions strike the cathode surface is

ADVANCE MANUFACTURING PROCESS

much less than the momentum with which the electron stream impinges on the anode surface.

(ii) A compressive force is generated on the cathode surface by the spark which helps reduce tool wear.

Most of the EDM operations are conducted with electrodes (tool and work) immersed in a liquid dielectric, for example paraffin, and the mechanism of sparking is similar to that described above except that the dielectric is contaminated with conductive particles. Furthermore, the particles removed from the electrodes due to the discharge fall in the liquid, cool down and contaminate the area around the electrodes by forming colloidal suspensions of metal. These suspensions, along with the products of decomposition of the liquid dielectric are drawn into the space between the electrodes during the initial part of the discharge process and are distributed

along the electric lines of force, thus forming current carrying bridges. Discharge then occurs along one of these bridges as a result of ionization

described earlier.

Spark discharge in liquid leads to an intense ejection of anode particles into the surrounding space, but discharge in a gas results in the partial transfer and diffusion of detached anode particles into the surface of the cathode. Both these phenomena are used in metal working; the first in performing dimensional working operations, for example, drilling, die sinking and the preparation of tool, etc.; the second is employed in operations connected with the toughening and building up of surfaces. The spark erosion process must be visualized as a succession of spark discharges distributed over the surface to be eroded. The spark will pass between the electrode and work piece at that particular point at which the electric field strength in the inter space is highest. Thus, successive spark discharges erode the entire surface. A surface produced by this method has a pitted appearance, the size and depth of the pits are determined by the spark energy, the nature of work-piece material and the dielectric.

Spark Erosion Generators

In the EDM process, electrical energy in the form of short duration impulses are required to be supplied to the machining gap. For this purpose, especially designed generators are employed. The generators for spark erosion are distinguished according to the way in which the voltage is transformed and the pulse is controlled, and also on the basis of the characteristics of discharge.

ADVANCE MANUFACTURING PROCESS

The discharge may be produced in a controlled manner by 'natural' ignition and relaxation, or by means of a controllable switching element, for example, electronic valve, thyristor, transistor, etc. The discharge may take place with constant or changing polarity.

On the basis of these facts, generators for EDM can be classified into:

- (i) Relaxation generators.
- (ii) Rotary pulse generators.
- (iii) Static pulse generators.

Relaxation Generators

The relaxation or the R-C circuit was the first to be used in EDM. The circuit (Fig. 4.12) comprises a D.C. power source that charges a capacitor 'C' across a resistance 'R'. If the condenser is initially uncharged and the D.C. supply is switched on, a heavy current will flow into the circuit with the condenser voltage rising continuously, as shown in Fig. 4.13.

The condenser voltage at the instant t can be described by the relationship

$$U_{1(t)} = U_s [1 - e^{-t/RC}] \quad (4.1)$$

Equation 4.1 predicts that the condenser voltage will approach the supply voltage (U_s) with a time constant equal to RC and after $t = RC$, the condenser voltage will be 63 per cent of the supply voltage (U_s). A discharge, across the working gap will occur if $U_{1(t)}$ equals the breakdown voltage (U_b) of the dielectric within the gap. After the discharge, the dielectric deionizes, the capacitor is recharged and the cycle repeats itself. The time taken to recharge the capacitor to the breakdown voltage must be sufficient to allow the dielectric to deionize.

In practice, the spark gap is adjusted so that the discharge takes place corresponding to a gap voltage of about $0.72 U_s$. Although a higher gap voltage would liberate much more energy, the time required to recharge the condenser increases. Thus, the benefit from a higher energy content per spark is more than offset by a reduction in the number of condenser discharge per unit time. It has been found in an R-C circuit, that for a given condenser and breakdown voltage, there exists a certain value of 'R' that will ensure correct length of the charging cycle.

ADVANCE MANUFACTURING PROCESS

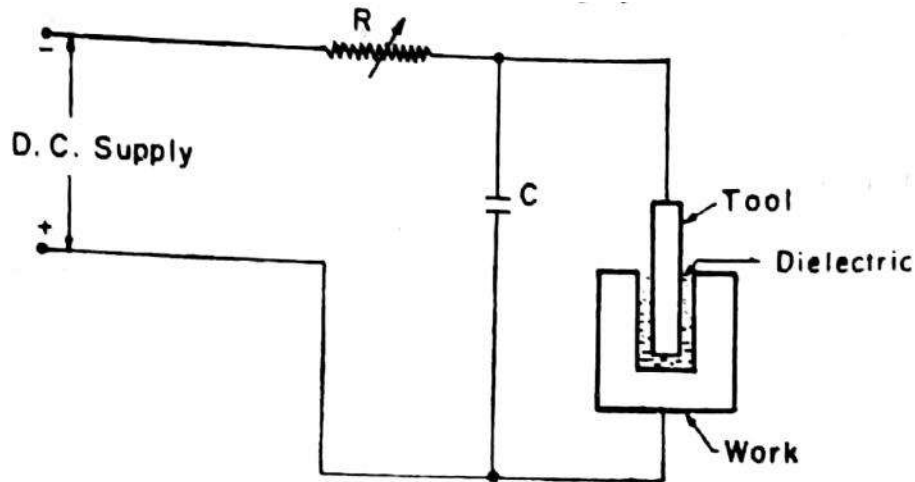

Fig. 4.12 Elementary relaxation circuit for EDM

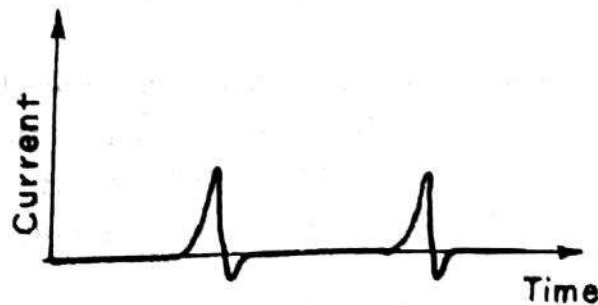
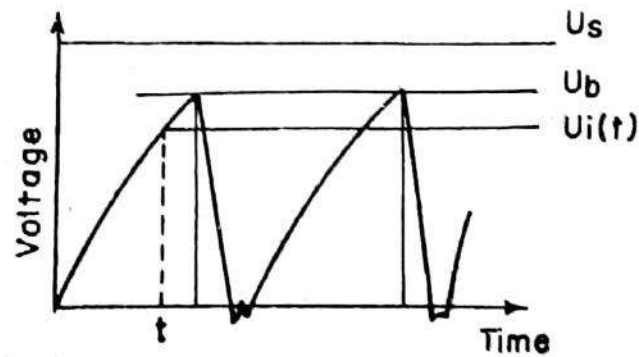

Fig. 4.13

In a relaxation generator, the spark repetition rate, for a given supply voltage and capacitance, cannot be increased beyond a critical value and is determined by the speed at which the spark gap is deionized and cleared of the debris after each discharge. Forced circulation of the dielectric through the gap is necessary if high metal removal rates are desired. As the working gap is of the order of 0.025-0.050 mm, forced circulation is difficult, especially when large electrodes are involved. In such cases, a lower erosion rate must be accepted than is possible with small size electrodes.

ADVANCE MANUFACTURING PROCESS

must be accepted than is possible with simple circuits. The fundamental advantages of relaxation circuits are their comparative cheapness, simplicity of design, robustness and relatively extensive range of discharge. They remain the only practical means of generating low energy ranges and high frequencies required for fine finishing and delicate operations.

In spite of many modifications of relaxation circuits, they are liable to result in high tool wear and slow metal removal rates, compared with other types of generators. Moreover, interdependence of parameters, such as discharge intensity and duration and energy values, creates a certain degree of inflexibility.

Electrode Feed Control

Since, during operation, both the work piece and electrode are eroded, the feed control must maintain a movement of the electrode towards the work piece at such a speed that the working gap, and hence, the sparking voltage remains unaltered. Since the gap width is so small, any tendency of the control mechanism to hunt is highly undesirable. Rapid response of the mechanism is essential and this implies a low inertia drive. Overshooting may completely close the gap and cause a short circuit; hence, it is essential to have rapid reversing speed with no backlash. Actuation of the control drive is derived from an error indication signal obtained from an electrical sensing device responsive to either the gap voltage or the working current or both. Servo-mechanisms affecting the movement of the electrode may be either electric-motor-driven, solenoid operated or hydraulically operated or a combination of these. An electric-motor-driven type of gap control mechanism is shown in Fig. 4.14. Here, the electrode is carried in a chuck fixed to a spindle, to which a rack is attached. The axial movement of the spindle is controlled through a reduction gear box driven by a D.C. shunt motor, which is reversible so that the electrode can be withdrawn, should the gap be bridged by swarf or the control mechanism cause the electrode to overshoot.

The motor armature is connected across a bridge network, the arms of which consist of a potential divider 'A' connected across the D.C. supply, while the other arm consists of the ballast resistance 'B' and condenser 'C' of the charging circuit, the latter arms also being connected across the supply. The control gear works as follows.

Assume the electrode to be initially widely spaced from the work piece

ADVANCE MANUFACTURING PROCESS

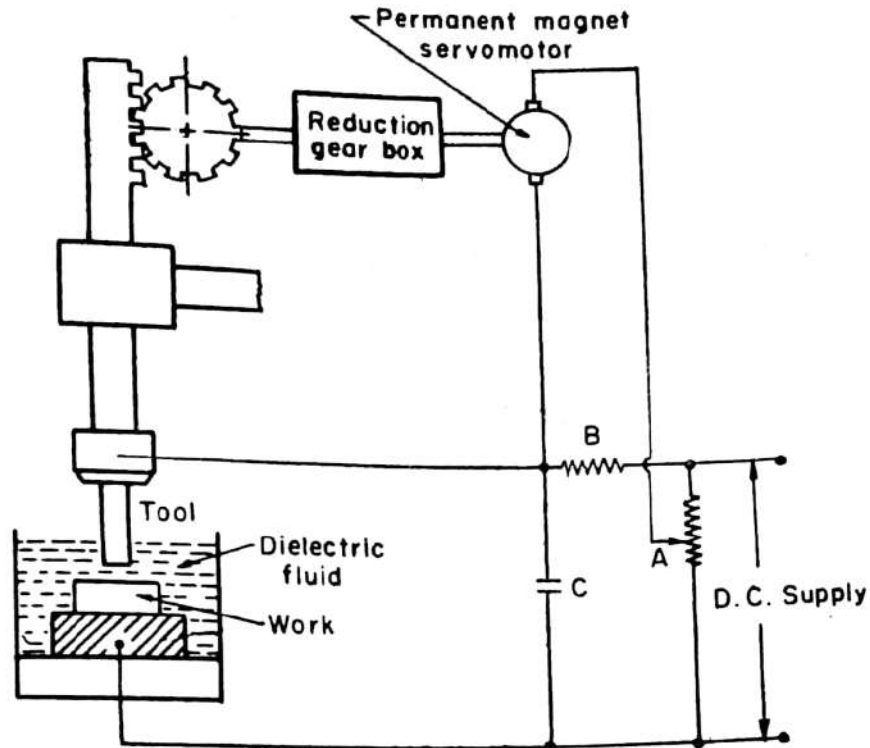

Fig. 4.14 Electrode feed control in EDM

and the current supply switched on to the condenser. This will cause the condenser to be charged and the voltage will rise to approach the supply voltage. The supply voltage will, therefore, prevail across one lower arm of the bridge. The voltage across the other arm of the bridge will depend on the potentiometer setting, and if this setting is midway, then the voltage across the bridge (i.e. the difference between voltages across the two lower limbs) will be half the supply voltage. This voltage tends to rotate the motor, causing the electrode to close the gap. When the electrode reaches the correct position, sparking takes place and the condenser rapidly charges and discharges so that a saw-tooth wave-form is produced across its terminals. The electrode will cease to move when the average value of this voltage equals that prevailing across the lower limb of the potentiometer. Under this condition, the bridge is balanced and there is no armature current. Should the electrode overshoot, the gap width will be smaller and the average condenser voltage will fall since the condenser will no longer be able to charge up to the specific voltage. The bridge is now unbalanced with a reverse polarity so the motor reverses and widens the gap until the correct position is attained. If the electrode touches the work, the condenser is short circuited, causing the supply voltage to appear across the ballast resistance, and the electrode is lifted away from the work piece. When the gap is bridged by swarf. The

ADVANCE MANUFACTURING PROCESS

Power delivered by an R-C circuit The relaxation circuit shown in Fig. 4.12 can be considered to be made up of the (i) charging circuit, and the (ii) discharging circuit.

The voltage $U_{i(t)}$ across the condenser in Fig. 4.12 at time t is given by

$$U_{i(t)} = U_s [1 - e^{-t/RC}] \quad (4.1)$$

and the charging current $i(t)$ would be equal to

$$i(t) = C \frac{dU_{i(t)}}{dt} \quad (4.2)$$

Substituting for U_s and integrating

$$i(t) = \frac{U_s}{R} e^{-t/RC} \quad (4.3)$$

Energy per spark is given by

$$E = \frac{1}{2} CU_b^2 \quad (4.4)$$

or

$$E = \frac{1}{2} C [U_s (1 - e^{-t'/RC})]^2 \quad (4.5)$$

where t' = charging time of the condenser up to the breakdown voltage. The power delivered in time t' (average) would be obtained as

$$E/t' = W_{\text{avg}} = \frac{C}{2t'} \left[U_s \left\{ 1 - e^{-t'/RC} \right\} \right]^2$$

For maximum power delivery through the circuit

$$\frac{dW_{\text{avg}}}{dx} = 0 \quad (4.6)$$

where

$$x = t'/RC$$

For maximum power, from Eq. 4.6, it is seen that $x = 1.26$

Substituting for x , we get

$$U_b = U_s [1 - e^{-1.26}]$$

or

$$\frac{U_b}{U_s} = 0.72 \quad (4.7)$$

Thus, it is seen that for maximum power delivery through the gap, the breakdown and supply voltage should follow the relationship given in Eq. 4.7.

Metal removal rate using relaxation circuit Metal removal rate in EDM, using relaxation type circuit, is proportional to the product of frequency of charging (f) and the energy delivered per spark.

ADVANCE MANUFACTURING PROCESS

Metal removal rate $\propto f \frac{1}{2} CU_b^2$
 or, Metal removal rate $= K_1 f (\frac{1}{2} CU_b^2)$
 where K_1 is the constant of proportionality.
 The frequency of charging would be given by

$$f = 1/t'$$

where t' , the time of charging the condenser is given by

$$t' = RC \log_e \left[\frac{1}{1 - U_b/U_s} \right]$$

The metal removal rate (MRR) is, therefore, given by

$$\text{MRR} = \frac{K_1}{2R} U_b^2 \times \left[\frac{1}{\log_e \frac{1}{1 - U_b/U_s}} \right] \quad (4.8)$$

From Eq. 4.8 and Fig. 4.15, it can be seen that for a given circuit, the metal removal rate will increase with decreasing R . However, R can not be made very low because, in that case, arcing will occur instead of sparking and such a situation is detrimental to the work surface finish. The minimum value of the resistance that will prevent arcing is known as critical resistance.

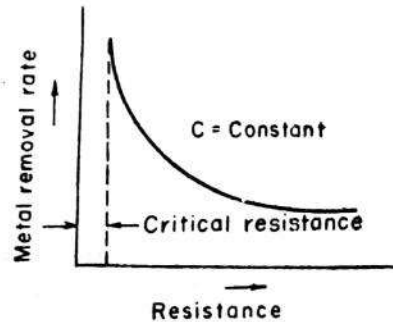

Fig. 4.15

Critical resistance If the equivalent inductance of the discharging circuit is considered to be L , then from the energy balance it is seen that

$$\frac{1}{2} Li_{d \max}^2 = \frac{1}{2} CU_b^2 \quad (4.9)$$

where $i_{d \max}$ = Maximum discharge current $= \frac{U_0}{\sqrt{L/C}}$, and

$$U_0 = \text{Condenser voltage at the instant of spark initiation} \quad (4.10)$$

at

$$i_{d \max} = U_s - U_c/R$$

ADVANCE MANUFACTURING PROCESS

For a purely inductive circuit

$$i_{d \max} = U_s / R_{\min} \quad (4.11)$$

Equating Eqs. 4.10 and 4.11, we get the minimum value of the resistance (R_{\min}) for a purely inductive circuit as

$$R_{\min} = \frac{U_s}{U_c} \sqrt{L/C} \quad (4.12)$$

For

$$\frac{U_s}{U_c} = 1, R_{\min} = \sqrt{L/C} \quad (4.13)$$

Equation 4.13 is found to be discordant with the experimental values. In practice, the circuit is not purely inductive, and hence, this equation should be used with modifications. The empirical relation given by Eq. 4.14 has been found to yield better results

$$R_{\min} \geq 30 \sqrt{L/C} \quad (4.14)$$

Rotary Pulse Generators

In order to increase the metal removal rates, motor generator sets have been developed to supply the required machining power in EDM. These generators are commonly referred to as the rotary pulse generators and produce asymmetric output waves so that the advantage of the equivalent of a d.c. power supply can be maintained. The basic circuit of a rotary pulse generator is given in Fig. 4.22. During operation, the capacitor 'C' is charged through the diode 'D' on half cycle. On the following half cycle, the sum of the voltage from the generator and charged capacitor is applied to the gap.

ADVANCE MANUFACTURING PROCESS

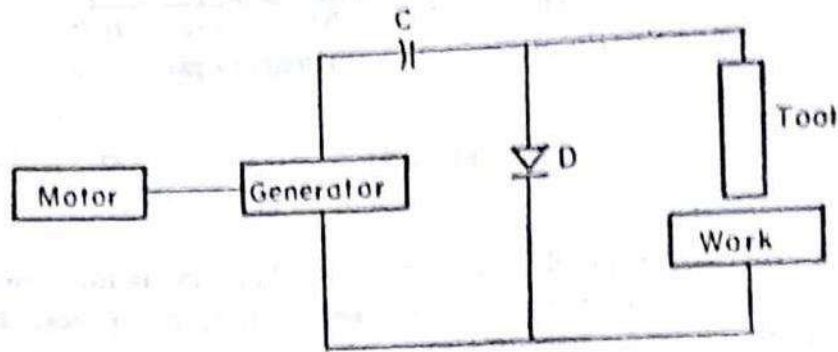

Fig. 4.22

This circuit allows a standard high frequency A.C. generator to be used to produce unidirectional pulses. This circuit permits high metal removal rates but produces exceedingly rough surfaces.

Controlled Pulse Circuit

In the electrical circuits discussed earlier, the switching device was a primary factor in determining the frequency and the amount of energy per discharge. One element of control lacking in the basic circuit is the ability to cut off the current in case of a short circuit. The method of breaking the short circuit in both relaxation and pulse generator circuits is to withdraw the electrode mechanically. However, this takes time and could lead to intensive work surface damage.

The need for a faster method of stopping the current in the event of short circuits resulted in the development of circuits with electronic tubes and transistors. These circuits are known as controlled pulse circuits (static pulse generator) and offer the advantage of faster rate of metal removal and low tool electrode wear.

The majority of spark erosion machines currently available employ transistorized pulse circuits which can achieve higher metal removal rates together with a high degree of accuracy. The use of controlled pulse generators enables wide variations in pulse duration frequency and in the intensity of spark discharges, and employs power transistor triodes as switching devices. These are switched by low power square wave generators and allow independent 'on' and 'off' controls, and the whole system provides unidirectional square-wave pulses to the electrodes.

A vacuum tube circuit is shown in Fig. 4.23. In this case, the resistor R in the R-C circuit is replaced by a series of vacuum tubes connected in

ADVANCE MANUFACTURING PROCESS

parallel. The electronic control circuit **BB** turns on the tube and the condenser gets charged. This also enables the current flow to stop in case of a short circuit.

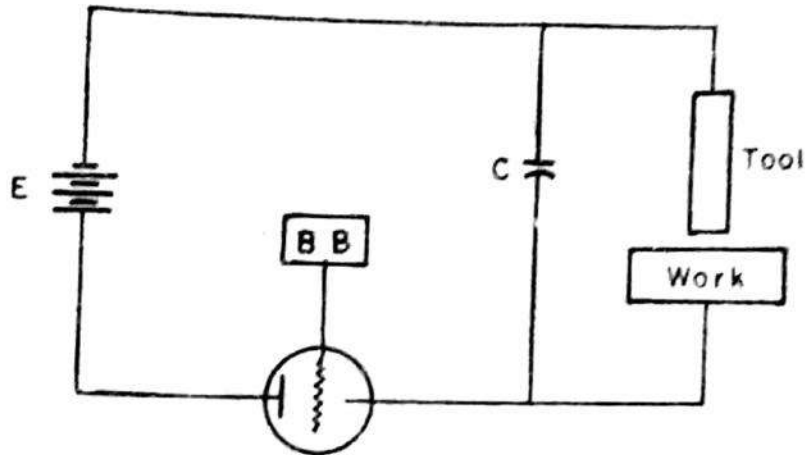

Fig. 4.23

The vacuum tube circuits require high voltages and low currents. Further improvement is possible by the use of transistors in place of vacuum tubes which are low voltage devices. Figure 4.24 illustrates a transistor circuit. In this circuit, switching is done by the oscillator at a selected imposed frequency and does not require the use of capacitors. The oscillator is also controlled by the gap conditions so that the transistors can be turned off in case of a short circuit.

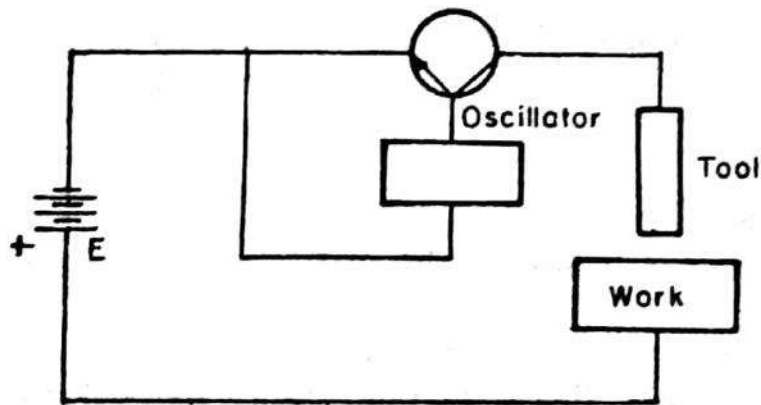

Fig. 4.24

ADVANCE MANUFACTURING PROCESS

Dielectric Fluids

For dielectric fluids to be used in EDM process, it is essential that they should

- (i) Remain electrically non conductive until the required breakdown voltage is reached, that is they should have high dielectric strength.
- (ii) Breakdown electrically in the shortest possible time once the breakdown voltage has been reached.
- (iii) Quench the spark rapidly or deionize the spark gap after the discharge has occurred.
- (iv) Provide an effective cooling medium.
- (v) Be capable of carrying away the swarf particles in suspension, away from the working gap.
- (vi) Have a good degree of fluidity.
- (vii) Be cheap and easily available.

Light hydro-carbon oils seem to adequately satisfy these requirements. The common fluids that can be used are transformer oil, paraffin oil, kerosene, lubricating oils or various petroleum distillate fractions. Recently, distilled water has also been used in place of dielectric fluid and this has been found to permit very high metal removal rates. Table 4.1 compares the performance of several dielectric fluids on brass tools, when used for machining steels.

Table 4.1

Dielectric fluid	Machining rate Work material removed $cm^3/amp\ min \times 10^4$	Wear ratio*
50 viscosity SSU } hydro-carbon oil }	39.0	2.8
Distilled water	54.6	2.7
Tap water	57.7	4.1
Tetraethylene glycol	102.9	6.8

*Wear ratio = $\frac{\text{volume of work material machined in unit time}}{\text{volume of electrode material worn out in unit time}}$

ADVANCE MANUFACTURING PROCESS

The dielectric should be filtered before re-use so that the contamination of the dielectric fluid will not affect machining accuracy. This is usually accomplished by filtration.

Flushing

Flushing is defined as the correct circulation of dielectric fluid between the electrodes and workpiece. Suitable flushing conditions are essential to obtain the highest machining efficiency. In order to comprehend the importance of correct flushing in EDM, it is necessary to understand the phenomenon that occurs in the machining gap when flushing is absent.

To start with, the dielectric is fresh, that is, it is free from eroded particles and carbon residue resulting from dielectric cracking, and its insulation strength is high. With successive discharges the dielectric gets contaminated, reducing its insulation strength, and hence, discharge can take place easily. If the density of the particles becomes too high at certain points

Injection Flushing

The dielectric fluid is injected continuously into the working gap either through the work piece or tool. A hole is provided in the work piece or tool for this purpose.

Suction Flushing

In this method, the fluid is sucked either through the work piece or the tool electrode. Compared with injection flushing, suction avoids taper effects due to sparking via particles along the sides of the electrode. Suction flushing through the tool rather than through the work piece has proved to be more efficient.

Side Flushing

When flushing holes cannot be drilled either in the work piece or the tool this type of flushing is employed. For the entire working area to be evenly flushed, special precautions have to be taken for the pumping of dielectric.

Flushing by Dielectric Pumping

Flushing is obtained by using the electrode pulsation movement. When the electrode is raised, the gap increases, resulting in clean dielectric being sucked into mix with contaminated fluid, and as the electrode is lowered, the particles are flushed out. This method has been found particularly suitable in deep hole drilling.

ADVANCE MANUFACTURING PROCESS

Application of EDM

The EDM process has the ability to machine hard, difficult-to-machine materials. Parts with complex, precise and irregular shapes for forging, press tools, extrusion dies, difficult internal shapes for aerospace and medical applications can be made by EDM process. Some of the shapes made by EDM process are shown in Figure 14.



Adv
The

- By this process, materials of any hardness can be machined;
- No burrs are left in machined surface;
- One of the main advantages of this process is that thin and fragile/brittle components can be machined without distortion;
- Complex internal shapes can be machined

Limitations of EDM

The main limitations of this process are:

- This process can only be employed in electrically conductive materials;

ADVANCE MANUFACTURING PROCESS

- Material removal rate is low and the process overall is slow compared to conventional machining processes;
- Unwanted erosion and over cutting of material can occur;
- Rough surface finish when at high rates of material removal.

Dielectric fluids

Dielectric fluids used in EDM process are hydrocarbon oils, kerosene and deionised water. The functions of the dielectric fluid are to:

- Act as an insulator between the tool and the workpiece.
- Act as coolant.
- Act as a flushing medium for the removal of the chips.

The electrodes for EDM process usually are made of graphite, brass, copper and copper-tungsten alloys.

Design considerations for EDM process are as follows:

- Deep slots and narrow openings should be avoided.
- The surface smoothness value should not be specified too fine.
- Rough cut should be done by other machining process. Only finishing operation should be done in this process as MRR for this process is low.

Wire EDM

EDM, primarily, exists commercially in the form of die-sinking machines and wire-cutting machines (Wire EDM). The concept of wire EDM is shown in Figure 15. In this process, a slowly moving wire travels along a prescribed path and removes material from the workpiece. Wire EDM uses electro-thermal mechanisms to cut electrically conductive materials. The material is removed by a series of discrete discharges between the wire electrode and the workpiece in the presence of dielectric fluid, which

ADVANCE MANUFACTURING PROCESS

creates a path for each discharge as the fluid becomes ionized in the gap. The area where discharge takes place is heated to extremely high temperature, so that the surface is melted and removed. The removed particles are flushed away by the flowing dielectric fluids.

The wire EDM process can cut intricate components for the electric and aerospace industries. This non-traditional machining process is widely used to pattern tool steel for die manufacturing.

The wires for wire EDM is made of brass, copper, tungsten, molybdenum. Zinc or brass coated wires are also used extensively in this process. The wire used in this process should possess high tensile strength and good electrical conductivity.

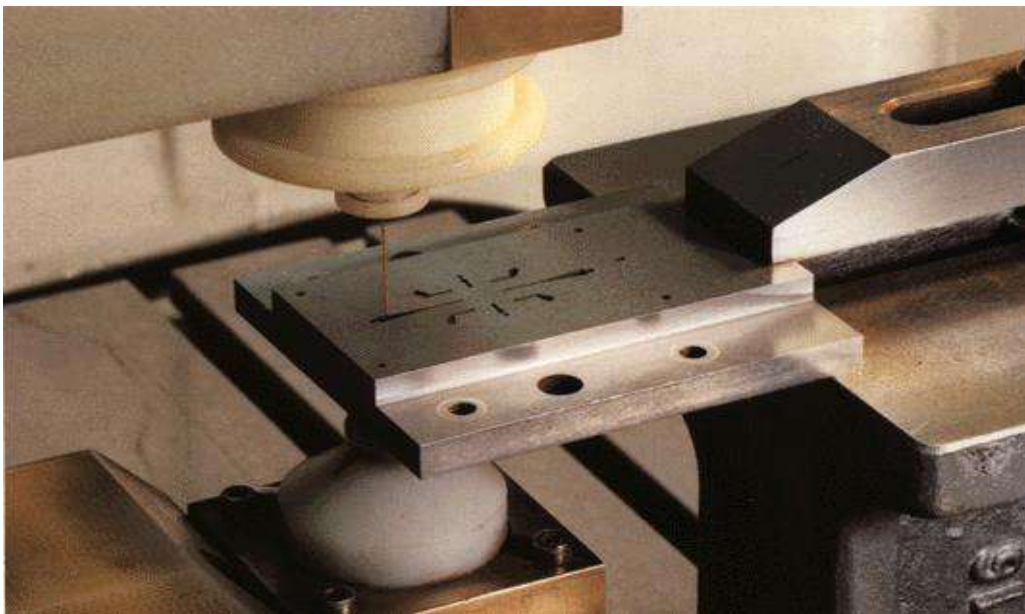

Figure 15: Wire erosion of an extrusion die

Wire EDM can also employ to cut cylindrical objects with high precision. The spark eroded extrusion dies are presented in Figure 16.

ADVANCE MANUFACTURING PROCESS

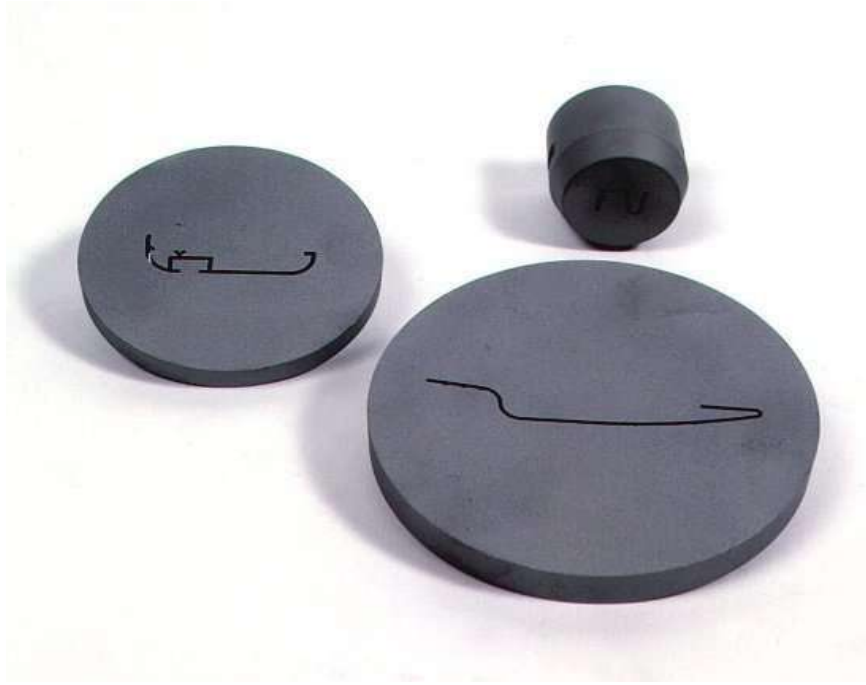

Figure 16: Sparked eroded extrusion dies

This process is usually used in conjunction with CNC and will only work when a part is to be cut completely through. The melting temperature of the parts to be machined is an important parameter for this process rather than strength or hardness. The surface quality and MRR of the machined surface by wire EDM will depend on different machining parameters such as applied peak current, and wire materials.

ADVANCE MANUFACTURING PROCESS

Module-III

PLASMA ARC MACHINING (PAM):

Introduction

A plasma is defined as a superheated, electrically ionized gas. Plasma Arc Cutting (PAC) uses a plasma stream operating at temperatures in the range from 10,000 to 14,000 °C to cut metal by melting. The cutting action takes place by directing the high velocity plasma stream at the work, thus melting it and blowing the molten metal through the kerf. Plasma is encountered in electrical discharges, such as fluorescent tubes and electric arcs, lightning, high temperature combustion flames and the sun. Most applications of PAC involve cutting of flat metal sheets and plates. Operations include hole piercing and cutting along a defined path. It was initially employed to cut metals that are difficult to machine by conventional methods. However, in recent years, PAC has also been used to cut plain carbon steel, stainless steel and aluminium.

Principle:

When heated to elevated temperatures, gases turn into a distinctly different type of matter, which is plasma. When gases are heated by an applied electric field, an igniter supplies the initial electrons, which accelerate in the field before colliding and ionizing the atoms. The free electrons, in turn, get accelerated and cause further ionization and heating of the gases. The avalanche continues till a steady state is obtained in which the rate of production of the free charges is balanced by recombination and loss of the free charges to the walls and electrodes. The actual heating of the gas takes place due to the energy liberated when free ions and electrons recombine into atoms or when atoms recombine into molecules.

Types of Plasma Arc Cutting system:

There are different types of plasma arc cutting operations. There are 2 main configurations.

- non-transferred mode,
- transfer mode

ADVANCE MANUFACTURING PROCESS

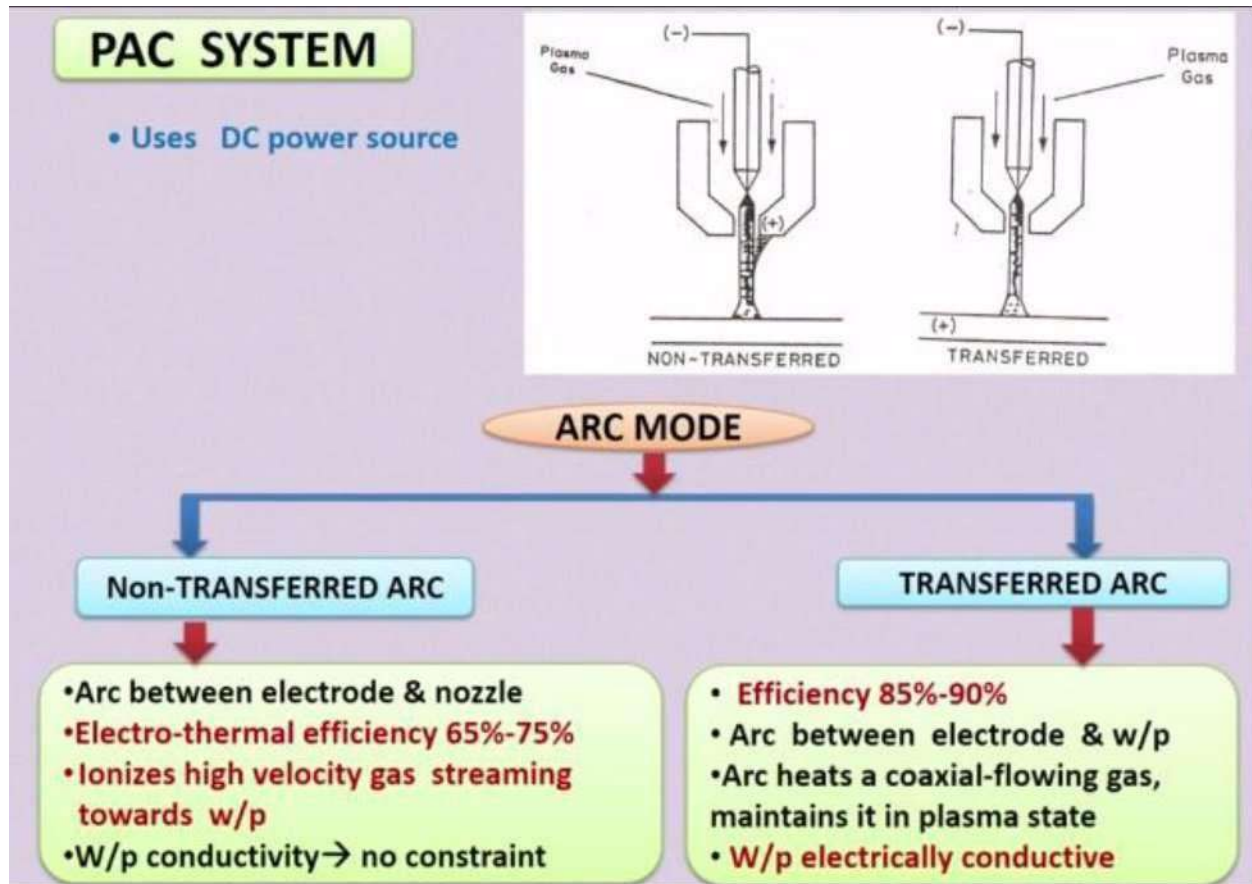

So this plasma gas is flowing surrounding this cathode. So this surrounding this cathode this plasma gas is coming and it is passing, this high velocity plasma gas is passing through this nozzle here. So it is passing through the nozzle. When it is passing through this nozzle, it is ionized, this plasma gas high pressurized, high velocity plasma gas is ionized and using this non- transferred mode any kind of material whether it is electrically conducting or electrically non-conducting, any kind of material can be cut or machined. So this non-transferred arc, arc between electrode and nozzle so this is arc is generated between this electrode and this nozzle. So here electrode this cathode and nozzle is connected to the anode and electrothermal efficiency of this kind of non-transferred arc is 65 to 70%. So it has a very low efficiency, low efficiency than this transferred mode. So ionizes high velocity gas streaming towards the workpiece when it is passing through this cathode or electrode and the nozzle so high velocity plasma jet is actually here, it is ionizes. So workpiece conductivity is not a

ADVANCE MANUFACTURING PROCESS

constant. So any kind of material, any kind of workpiece material, whether it is electrically conducting or non-conducting, any kind of material can be cut by this plasma, non-transferred mode of plasma arc cutting operation.

But in this transferred mode you can see here this is the electrode here and this positive terminal is connected to the workpiece. So here the main constant is that this workpiece should be electrically conducting material. So this kind of transferred mode can be used only for electrically conducting mode of electrically conducting workpiece material. So here plasma gas is coming surrounding this electrode and while it is passing through this so it is ionized here in this zone it is ionized while it is passing through this nozzle it is ionized.

So electrical efficiency, electrothermal efficiency of this kind of transfer mode, it is higher than this non-transfer mode, here it is 85 to 90% electrothermal efficiency for transferred mode or plasma arc nozzle. So arcing is generated between the electrode and the workpiece and arc heats of this coaxial-flowing gas so this is coaxial flowing plasma gas okay so maintains it in a plasma state. So here this workpiece is electrically conducting. So these are the 2 modes arc mode, one is the non-transferred and second one is the transferred arc mode.

Equipment

Elements of Plasma Arc system are

- power supply
- Gas supply
- Cooling water system
- Control console
- Plasma torch

So first one is the power supply. Second one is the gas supply, plasma gas supply system, then cooling water system. So you have to cool down this nozzle as well as the plasma jet you have to cool down and then control console. So this plasma jet can be controlled by using a CNC machining system or this working table may be controlled by using a CNC machining system, CNC system so that any complicated contour can be cut from the workpiece material and also the fifth one is the fifth one of the plasma arc system, plasma arc cutting system is the plasma torch.

ADVANCE MANUFACTURING PROCESS

Mechanism of material removal:

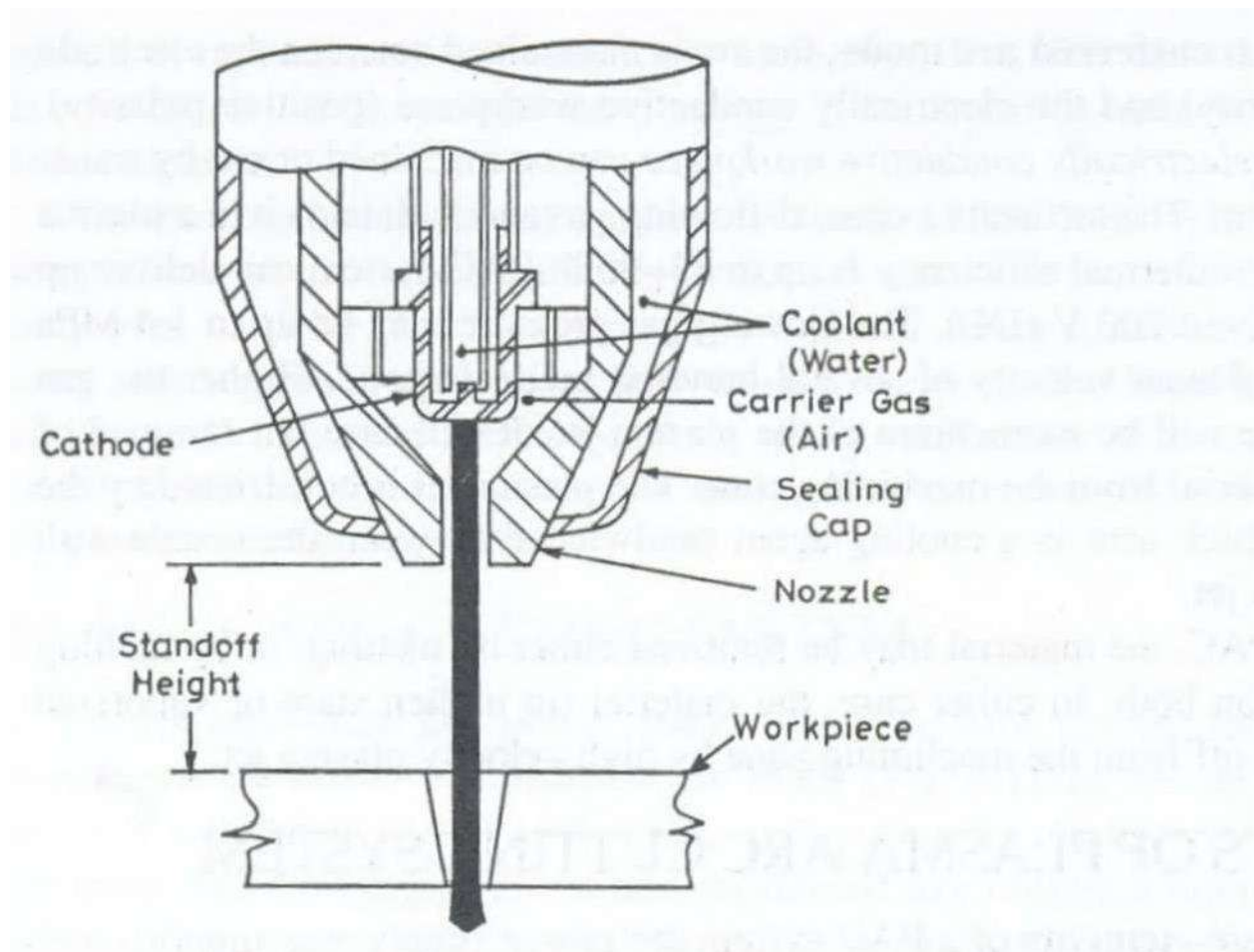

Fig. 9.2 Details of air plasma torch construction [*Benedict, 1987*;
Courtesy: W.A. Whitney Corp. Rockford, III.]

The metal removal in PAM is basically due to the high temperature produced. The heating of the work piece is, as a result of anode heating, due to direct electron bombardment plus convection heating from the high temperature plasma that accompanies the arc. The heat produced is sufficient to raise the work piece temperature above its melting point and the high velocity gas stream effectively blows the molten metal away.

Process Parameters:

Parameters that govern the performance of PAM can be divided into three categories:

1. Those associated with the design and operation of the torch –electrical power delivered , the gases used to form the plasma, the

ADVANCE MANUFACTURING PROCESS

flow rate of the gases through the torch, the orifice diameter through the nozzle duct.

2. Those associated with the physical configuration of the set up – torch standoff, angle to the work, depth of cut, feed into the work and speed of the work toward the torch.
3. Environment in which the work is performed – cooling that is done on the bar, any protective type of atmosphere used to reduce oxidation for the exposed high temperature machined surface and any means that might be utilized to spread out or deflect the arc and plasma impingement area.

Gas Cutting	PAM
<p>1. Oxidation of the work piece melted generates the heat to melt the material for (e.g) in cutting steel, fuel gas is used to heat it to 760⁰-870⁰C at while steel reacts rapidly with oxygen to form iron oxide. The heat generated by the burning iron is sufficient to melt the iron oxide.</p> <p>2. Oxy-fuel gas cutting is mostly limited to only ferrous metal especially plain carbon steels.</p> <p>3. Cutting speed are lower for (e.g) in cutting mild steel 19mm thick can be cut at 500 mm /min.</p> <p>4. Operating costs are higher</p> <p>5. Limited to the max. temperature of the chemical reaction (burning)</p> <p>6. Cost of equipment is lower. Surfaces are less smoother than those cut by PAM</p>	<p>1. Plasma is generated by subjecting a volume of gas to electron bombardment of an electric arc. The anode heating due to direct electron bombardment plus convective heating from the high temp plasma raises the material to the molten point and the high velocity gas stream effectively blows the material away.</p> <p>2. Because of the high temp involved, the process can be used on almost all material including those which are resistant to oxy-fuel gas cutting</p> <p>3. Cutting speeds are higher and leave a narrower kerf. They can cut mild steel 19mm thick at the rate of 1775mm /min.</p> <p>4. Operating costs are lower. Ratio of savings in favor of PAM is about 3:1</p> <p>5. Seems to be unlimited. The greater the power used, the greater the volume of kerf material that can be removed.</p> <p>6. High initial cost of the equipment. 7. Surfaces cut by plasma torch are smoother but the edges are rounded.</p>

ADVANCE MANUFACTURING PROCESS

Advantages

- The main advantage of PAM is speed. For example, mild steel of 6mm thick can be cut at 3m/min
- The plasma arc can be used to cut any metal or even to nonconducting materials like concrete etc., since it is primarily a melting process
- Due to high speed of cutting the deformation of sheet metals is reduced while the width of the cut is minimum
- Owing to the high productivity of the plasma arc cutting coupled with the tendency to use cheap and easily available plasma-forming media (air, water, ammonia etc.), PAC is finding ever increasing application.
- Smooth cuts free from contaminants are obtained in the process
- Profile cutting of metals especially of stainless steel and aluminium can be very easily done by PAM
- Operating costs are less when compared to oxy-fuel torch
- Can be automated

Limitations

- The main disadvantage of PAC is the high initial cost of the equipment. However, it can be made economical, if the quantity involved is large and the thickness is up to 50mm.
- Well-attached drops on the underside of the cut can be a problem and there will be heat affected zone (HAZ). The depth of HAZ depends on the material and its thickness
- Smoke and noise
- Sharp corners are difficult to produce because of the wide diameter of the plasma stream
- Burr is often produced
- Taper on the work-piece may occur

Applications

- Chiefly used to cut stainless steel and aluminium alloys. It is preferred to oxy-fuel cutting because it produces comparatively smoother cuts and is free from contamination

ADVANCE MANUFACTURING PROCESS

- Other metals which are resistant to oxy-fuel cutting and hence cut by PAC are magnesium, titanium, copper, nickel and alloys of copper and nickel
- PAC can be used for stack cutting, plate beveling, shape cutting and piercing.
- It can also be used for underwater cutting.
- The plasma jets are used for welding materials like titanium, stainlesssteel etc.,
- Plasma arc is used for depositing filler metal on surface to obtain desired properties like corrosion resistance, wear resistance, toughness or anti-friction properties – Plasma arc surfacing
- The plasma arc can also be used for spraying a prepared surface of the base material with droplets of molten metal to obtain a surface of required thickness

ADVANCE MANUFACTURING PROCESS

Laser-Beam Machining (LBM)

Laser-beam machining is a thermal material-removal process that utilizes a high-energy, coherent light beam to melt and vaporize particles on the surface of metallic and non-metallic workpieces. Lasers can be used to cut, drill, weld and mark. LBM is particularly suitable for making accurately placed holes. A schematic of laser beam machining is shown in Figure 17.

Different types of lasers are available for manufacturing operations which are as follows:

- CO₂ (pulsed or continuous wave): It is a gas laser that emits light in the infrared region. It can provide up to 25 kW in continuous-wave mode.
- Nd:YAG: Neodymium-doped Yttrium-Aluminum-Garnet (Y₃Al₅O₁₂) laser is a solid-state laser which can deliver light through a fibre-optic cable. It can provide up to 50 kW power in pulsed mode and 1 kW in continuous-wave mode.

□

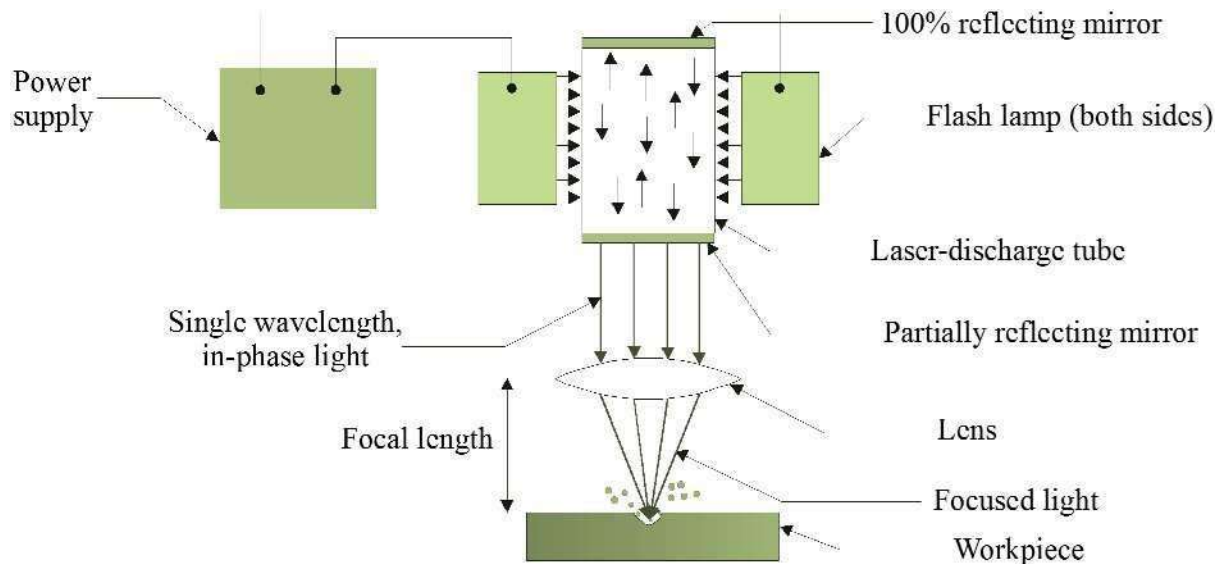

Figure 17: Laser beam machining schematic

ADVANCE MANUFACTURING PROCESS

Laser beam cutting (drilling)

- In drilling, energy transferred (e.g., via a Nd:YAG laser) into the workpiece melts the material at the point of contact, which subsequently changes into a plasma and leaves the region.
- A gas jet (typically, oxygen) can further facilitate this phase transformation and departure of material removed.
- Laser drilling should be targeted for hard materials and hole geometries that are difficult to achieve with other methods.

A typical SEM micrograph hole drilled by laser beam machining process employed in making a hole is shown in Figure 18.

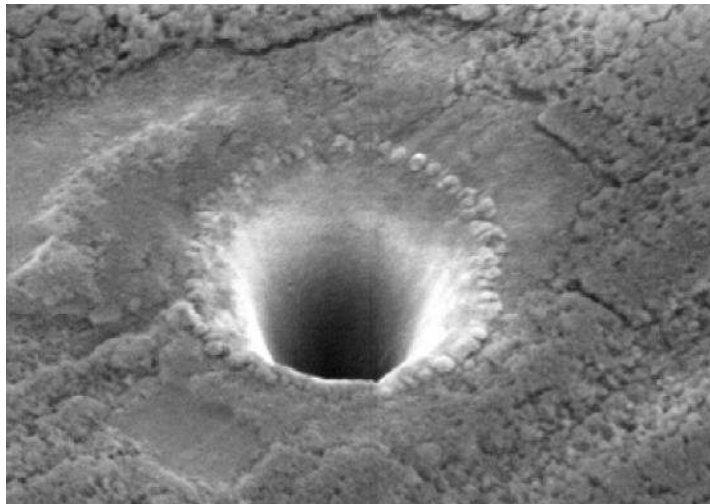

Figure 18: SEM micrograph hole drilled in 250 micro meter thick Silicon Nitride with 3rd harmonic Nd: YAG laser

Laser beam cutting (milling)

- A laser spot reflected onto the surface of a workpiece travels along a prescribed trajectory and cuts into the material.

ADVANCE MANUFACTURING PROCESS

- Continuous-wave mode (CO₂) gas lasers are very suitable for laser cutting providing high-average power, yielding high material-removal rates, and smooth cutting surfaces.

Advantage of laser cutting

- No limit to cutting path as the laser point can move any path.
- The process is stress less allowing very fragile materials to be laser cut without any support.
- Very hard and abrasive material can be cut.
- Sticky materials are also can be cut by this process.
- It is a cost effective and flexible process.
- High accuracy parts can be machined.
- No cutting lubricants required
- No tool wear
- Narrow heat affected zone

Limitations of laser cutting

- Uneconomic on high volumes compared to stamping
- Limitations on thickness due to taper
- High capital cost
- High maintenance cost
- Assist or cover gas required

Applications

- LBM can make very accurate holes as small as 0.005 mm in refractory metals ceramics, and composite material without warping the workpieces.
- This process is used widely for drilling and cutting of metallic and non-metallic materials.
- Laser beam machining is being used extensively in the electronic and automotive industries.

ADVANCE MANUFACTURING PROCESS

Electron Beam Machining (EBM)

In electron beam machining process there is a bombardment of high velocity stream of electrons on the work-piece surface so this electrons are bombarded on the work piece surface with a very high velocity, around 66% velocity of the sunlight so because of this bombardment of electrons on the work piece surface the materials into a small area on the work piece surface it melts and vaporizes and temperature rises to a very high temperature. So material on the work piece surface melts and vaporizes and machining is going on.

So this process actually it is used for machining thousands of holes on a thin sheet which is used in aerospace industry, food processing industry, cloth industries and very high aspect ratio for making of very high aspect ratio holes, thousands of holes on a work piece surface irrespective of the material property like metallurgical property, mechanical property of the material.

So this material maybe electrically conducting or electrically non- conducting or maybe ceramics, metals, or any kind of metal, any kind of ceramics it works. So here there is a filament which is heated with a very high temperature. So because of this heating of this filament so electrons emanates from that cathode, cathode filament or these filament may be heated from a radiation from a another body, from the radiation from a another body on a solid block of cathode, on a solid block of filament also it can be generated. So these electrons emits from the cathode, cathode filament and it passes through a magnetic lens to coincide to concentrate or to reduce the diameter of the electron beam and it bombards on the work piece surface.

Types of EBM

Electron beam machining process there are 2 types of methods are there. One is the **thermal type**. Another one is the **non-thermal type**. So in normal in non-thermal type this electron beams are used for generating chemical reactions. So for generating chemical reactions the electron beams are used. So this non-thermal type we are not going to discuss. We are going to discuss only thermal type of electron beam machining process.

ADVANCE MANUFACTURING PROCESS

In thermal type this cathode is heated to a very high temperature. So this stream of large number of electrons comes as a small diameter beam, electron beam.

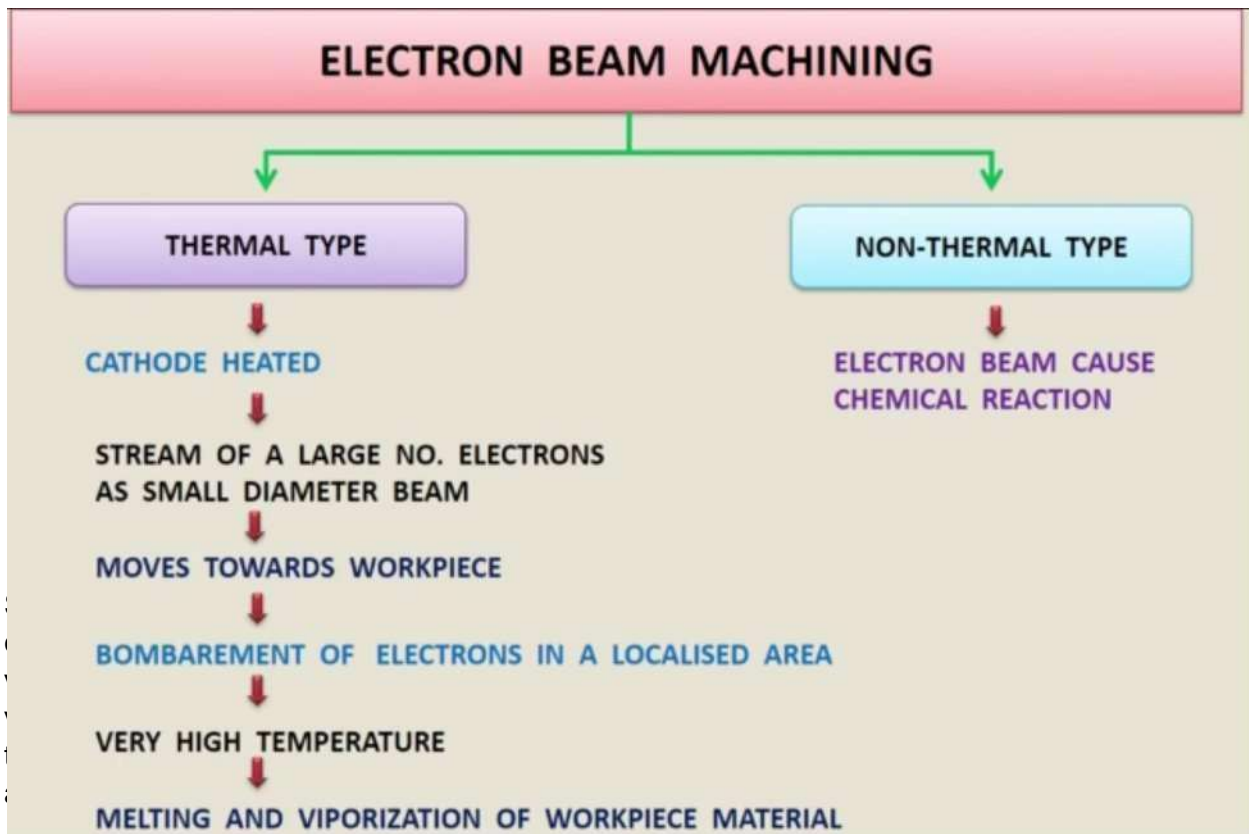

Equipment and working of EBM

Fig. below shows the schematic representation of an electron beam gun, which is the heart of any electron beam machining facility. The basic functions of any electron beam gun are to generate free electrons at the cathode, accelerate them to a sufficiently high velocity and to focus them

ADVANCE MANUFACTURING PROCESS

over a small spot size. Further, the beam needs to be manoeuvred if required by the gun. The cathode as can be seen in Fig. is generally made of tungsten or tantalum. Such cathode filaments are heated, often inductively, to a temperature of around 2500 C. Such heating leads to thermo-ionic emission of electrons, which is further enhanced by maintaining very low vacuum within the chamber of the electron beam gun. Moreover, this cathode cartridge is highly negatively biased so that the thermo-ionic electrons are strongly repelled away from the cathode. This cathode is often in the form of a cartridge so that it can be changed very quickly to reduce down time in case of failure.

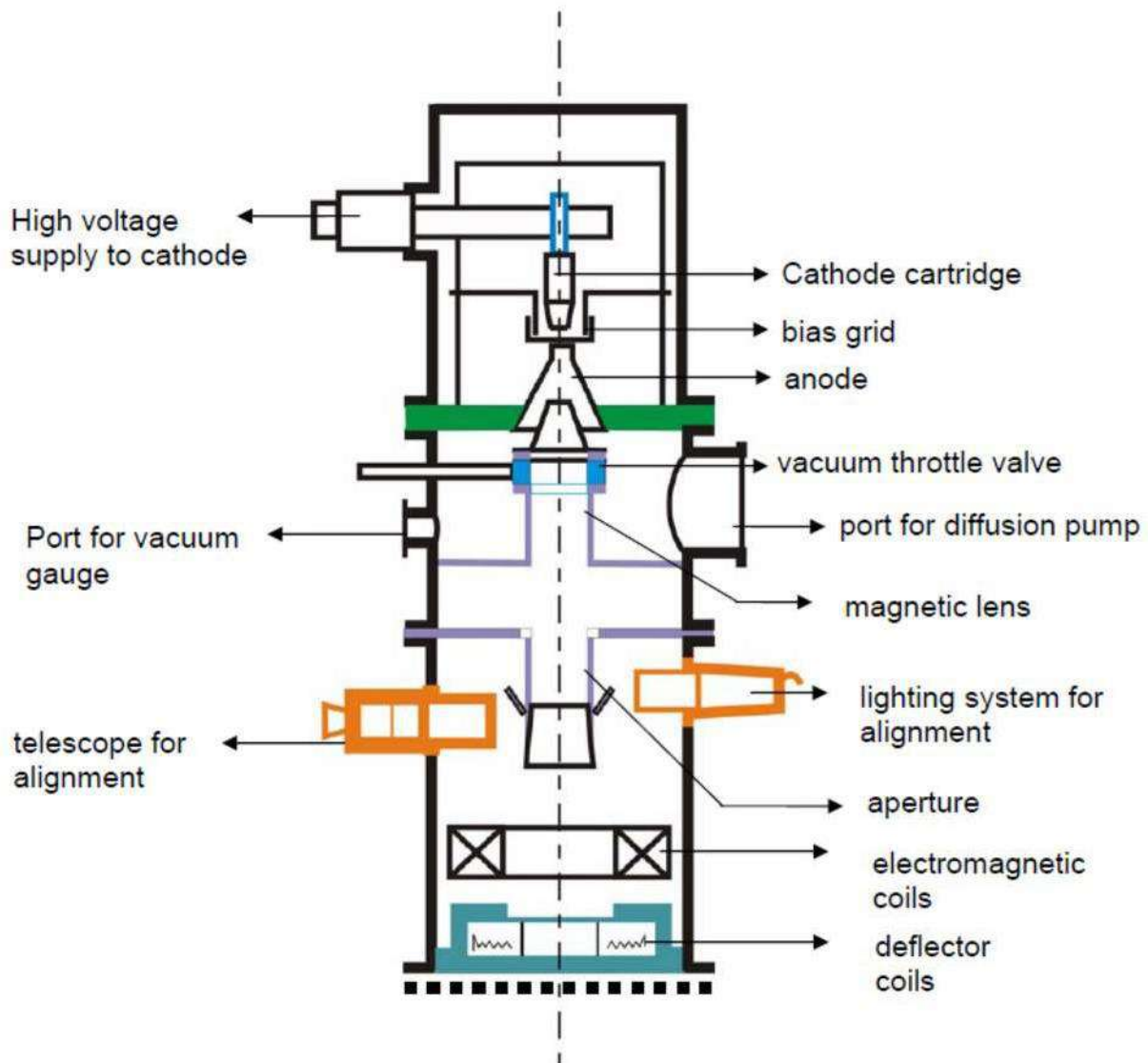

ADVANCE MANUFACTURING PROCESS

Just after the cathode, there is an annular bias grid. A high negative bias is applied to this grid so that the electrons generated by this cathode do not diverge and approach the next element, the annular anode, in the form of a beam. The annular anode now attracts the electron beam and gradually gets accelerated. As they leave the anode section, the electrons may achieve a velocity as high as half the velocity of light.

The nature of biasing just after the cathode controls the flow of electrons and the biased grid is used as a switch to operate the electron beam gun in pulsed mode.

After the anode, the electron beam passes through a series of magnetic lenses and apertures. The magnetic lenses shape the beam and try to reduce the divergence. Apertures on the other hand allow only the convergent electrons to pass and capture the divergent low energy electrons from the fringes. This way, the aperture and the magnetic lenses improve the quality of the electron beam.

Then the electron beam passes through the final section of the electromagnetic lens and deflection coil. The electromagnetic lens focuses the electron beam to a desired spot. The deflection coil can manoeuvre the electron beam, though by small amount, to improve shape of the machined holes.

Generally in between the electron beam gun and the workpiece, which is also under vacuum, there would be a series of slotted rotating discs. Such discs allow the electron beam to pass and machine materials but helpfully prevent metal fumes and vapour generated during machining to reach the gun. Thus it is essential to synchronize the motion of the rotating disc and pulsing of the electron beam gun.

Electron beam guns are also provided with illumination facility and a telescope for alignment of the beam with the workpiece.

Workpiece is mounted on a CNC table so that holes of any shape can be machined using the CNC control and beam deflection in-built in the gun.

One of the major requirements of EBM operation of electron beam gun is maintenance of desired vacuum. Level of vacuum within the gun is in the order of 10^{-4} to 10^{-6} Torr. {1 Torr = 1mm of Hg} Maintenance of suitable vacuum is essential so that electrons do not lose their energy and a significant life of the cathode cartridge is obtained. Such vacuum is achieved and maintained using a combination of rotary pump and diffusion

ADVANCE MANUFACTURING PROCESS

pump. Diffusion pump, as shown in Fig. 9.6.4 is attached to the diffusion pump port of the electron beam gun (vide Fig. 9.6.3).

Diffusion pump is essentially an oil heater. As the oil is heated the oil vapour rushes upward where gradually converging structure as shown in Fig. 9.6.4 is present. The nozzles change the direction of motion of the oil vapour and the oil vapour starts moving downward at a high velocity as jet. Such high velocity jets of oil vapour entrain any air molecules present within the gun. This oil is evacuated by a rotary pump via the backing line. The oil vapour condenses due to presence of cooling water jacket around the diffusion pump.

Electron Beam Process – Parameters

The process parameters, which directly affect the machining characteristics in Electron Beam Machining, are:

- The accelerating voltage
- The beam current
- Pulse duration
- Energy per pulse
- Power per pulse
- Lens current
- Spot size
- Power density

As has already been mentioned in EBM the gun is operated in pulse mode. This is achieved by appropriately biasing the biased grid located just after the cathode. Switching pulses are given to the bias grid so as to achieve pulse duration of as low as 50 μ s to as long as 15 ms.

Beam current is directly related to the number of electrons emitted by the cathode or available in the beam. Beam current once again can be as low as 200 μ amp to 1 amp.

Increasing the beam current directly increases the energy per pulse. Similarly increase in pulse duration also enhances energy per pulse. High-energy pulses (in excess of 100 J/pulse) can machine larger holes on thicker plates.

The energy density and power density is governed by energy per pulse duration and spot size. Spot size, on the other hand is controlled by the degree of focusing achieved by the electromagnetic lenses. A higher

ADVANCE MANUFACTURING PROCESS

energy density, i.e., for a lower spot size, the material removal would be faster though the size of the hole would be smaller.

The plane of focusing would be on the surface of the workpiece or just below the surface of the workpiece. This controls the kerf shape or the shape of the hole as schematically shown in Fig. 9.6.5.

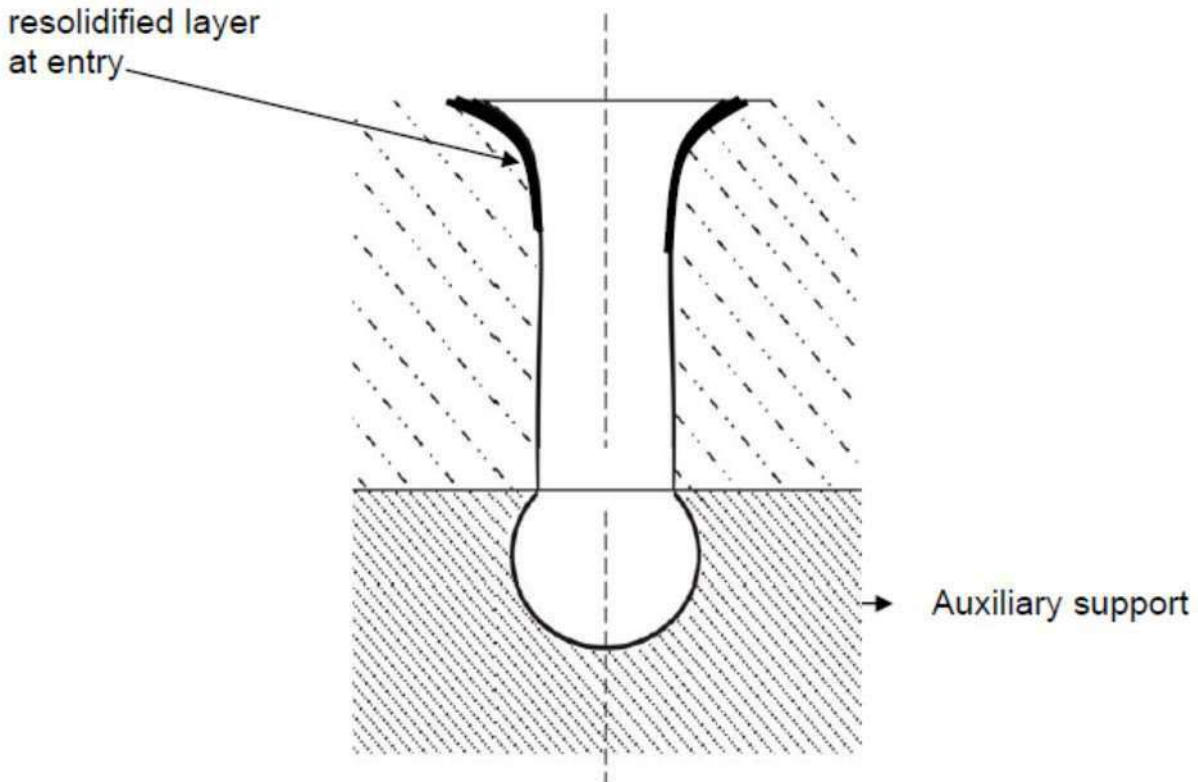

Typical kerf shape of electron beam drilled hole

As has been indicated earlier, the final deflection coil can manoeuvre the electron beam providing holes of non-circular cross-section as required.

Advantages

- EBM provides very high drilling rates when small holes with large aspect ratio are to be drilled.
- Moreover it can machine almost any material irrespective of their mechanical properties. As it applies no mechanical cutting force, workholding and fixturing cost is very less.

ADVANCE MANUFACTURING PROCESS

- Further for the same reason fragile and brittle materials can also be processed.
- The heat affected zone in EBM is rather less due to shorter pulses.
- EBM can provide holes of any shape by combining beam deflection using electromagnetic coils and the CNC table with high accuracy.

Limitations

- The primary limitations are the high capital cost of the equipment and necessary regular maintenance applicable for any equipment using vacuum system.
- Moreover in EBM there is significant amount of non-productive pump down period for attaining desired vacuum.
- However this can be reduced to some extent using vacuum load locks.
- Though heat affected zone is rather less in EBM but recast layer formation cannot be avoided.

APPLICATIONS

- **More popular** → aerospace, insulation, food processing & chemical, clothing, etc.
- **Hundreds to thousands of holes** (simple & complex shaped) in a workpiece (perforation of sheets) ← **complex shaped, difficult to machine material**

Example :

- Drilling thousands of holes (dia < 1 mm) in very thin plates used for **turbine engine combustor dome**
- Many thousand holes (dia < 1 mm) in cobalt alloy fibre spinning head of thickness 5 mm
Drilling by EBM claimed 100 times faster than EDM
- **Holes in filters & screens** ← **food processing industry**
- **Fine gas orifice in space nuclear reactor**
- **Holes in wire drawing dies**
- **Cooling holes in turbine blades**
- **Metering holes in injector nozzles of diesel engine**

ADVANCE MANUFACTURING PROCESS

Module-IV

Introduction to Surface engineering

The majority of material failure originates at surface by mechanism involving wear, corrosion and fatigue. In case of metals, one technique for controlling surface initiated failure is through use of alloying elements throughout the bulk of these specimens to suitably modify the hardness, chemical passivity or strength characteristics. However this method is considered inefficient due to the use of costly strategic alloying elements like Chromium(Cr) and Cobalt (Co). The reorganization that vast majority of engineering components fails catastrophically in service through surface related phenomena, led to the development of broad interdisciplinary subject of "Surface Engineering". Surface Engineering could be best defined as design of surface and substrate together as a system to give cost effective performance enhancement of which neither is capable of its own. The definition of surface engineering is given as "The application of traditional and innovative surface technologies to engineering components and materials with properties unattainable in either the base metal or surface materials". Frequently the various surface technologies are applied to existing design of engineering components but ideally surface engineering involves design of component with knowledge of surface treatment to be employed. OR As per Definition by ASM Handbook treatment of the surface and near-surface regions of a material to allow the surface to perform functions that are distinct from those functions demanded from the bulk of the material. Surface engineering, is a discipline of science and technology, which meets the expectations of modern technical science: energy, material efficiency, as well as environment friendliness.

CLASSIFICATION OF SURFACE ENGINEERING

(I) **Changing the Surface Metallurgy**: None of these process changes the surface chemistry, but they improve properties like wear and fatigue by changing surface metallurgy

a) Localized surface hardening (flame, induction, laser, and electron- beam hardening): Improves wear resistance through the development of a hard martensitic surface.

(b) Laser melting: Improves wear resistance through grain refinement and the formation of fine dispersions of precipitates on the surface.

ADVANCE MANUFACTURING PROCESS

c) Shot peening:

Shot peening is a surface enhancement process which produces beneficial compressive residual stresses on metallic surfaces. This improves fatigue strength and relieves tensile stresses that contribute to stress-corrosion cracking.

(II) Changing the Surface Chemistry Surface modification processes have advantage over coating primarily because they

- (1) usually impart internal compressive stresses in near surface region and
- (2) Will not delaminate off the substrate.

The process includes:

- (a) Chemical or electrochemical conversion treatment that produce complex phosphates, chromates/oxides on metal surface.
- (b) Thermo chemical diffusion heat treatment that involves the introduction of interstitial elements like C, N or B into ferrous alloy surface at elevated temperature.
- (c) Pack cementation diffusion treatments that involve the introduction of aluminium(Al), Cr or silicon(Si) into alloy surface.
- (d) Surface modification by ion implantation, which involves introduction of ionized species (virtually any element) into the substrate using ion beam of high velocity electrons.
- (e) Surface modification by combination of laser beam melting and alloying.

(III) Adding a Surface Layer or Coating This involves an intentional buildup or addition of new layer on metal substrate i.e. application of coating or lining. A wide range of processes are used to deposit metal/ceramic and Organic (paints or plastic and rubber coating).

Coating methods commonly used are:

- I. Organic coatings and lining
- II. Ceramic coatings
- III. Hot dip metallic coatings
- IV. Electroplating (metal or composite coating)
- V. Weld overlays (metal or ceramic coating)
- VI. Cladding (thick metal coating)
- VII. Thermo reactive deposition/diffusion process (carbides, nitrides or carbonitrides)

ADVANCE MANUFACTURING PROCESS

Amongst all the above methods of coating deposition, ceramic coatings have advantages since Ceramic materials are noted for their high hothardness and good chemical and thermal stability, making their surface properties ideal for number of engineering products, which encounter demanding operating conditions. The deposition of ceramic phases onto conventional metallic materials results in good combination of bulk toughness and load support with desirable surface characteristics and also making forming of complex shapes easier.

METHODS OF DEPOSITING CERAMIC COATINGS:

1. Thermal Spraying:
2. Sol Gel technique
3. Chemical Vapor Deposition Technique (CVD)
4. Physical Vapor Deposition Technique (PVD)

Thermal Spraying Thermal spray is one of the most versatile deposition processes for coating materials and its use for industrial applications has been greatly increase. Thermal spraying is, in fact, a generic group of processes in which the coating material is fed to a heating zone, where it becomes molten, and is then propelled to the surface to be coated .Metallic, ceramic, cermets and some polymeric materials can be used in the form of powder, wire, or rod for this purpose. (Fig 1.4.1)

Sol Gel technique The sol-gel technique is based on hydrolysis of liquid precursors at low temperature and formation of colloidal sols. (Fig 1.4.2)

Chemical Vapor Deposition Technique (CVD) CVD involves flowing a precursor gas or gases into a chamber containing one or more heated objects to be coated. Chemical reactions occurs on or near the hot surfaces resulting in deposition of thin films on the substrate, this is accompanied by the production of chemical byproducts that are exhausted out of chamber along with unreacted precursor gases.

ADVANCE MANUFACTURING PROCESS

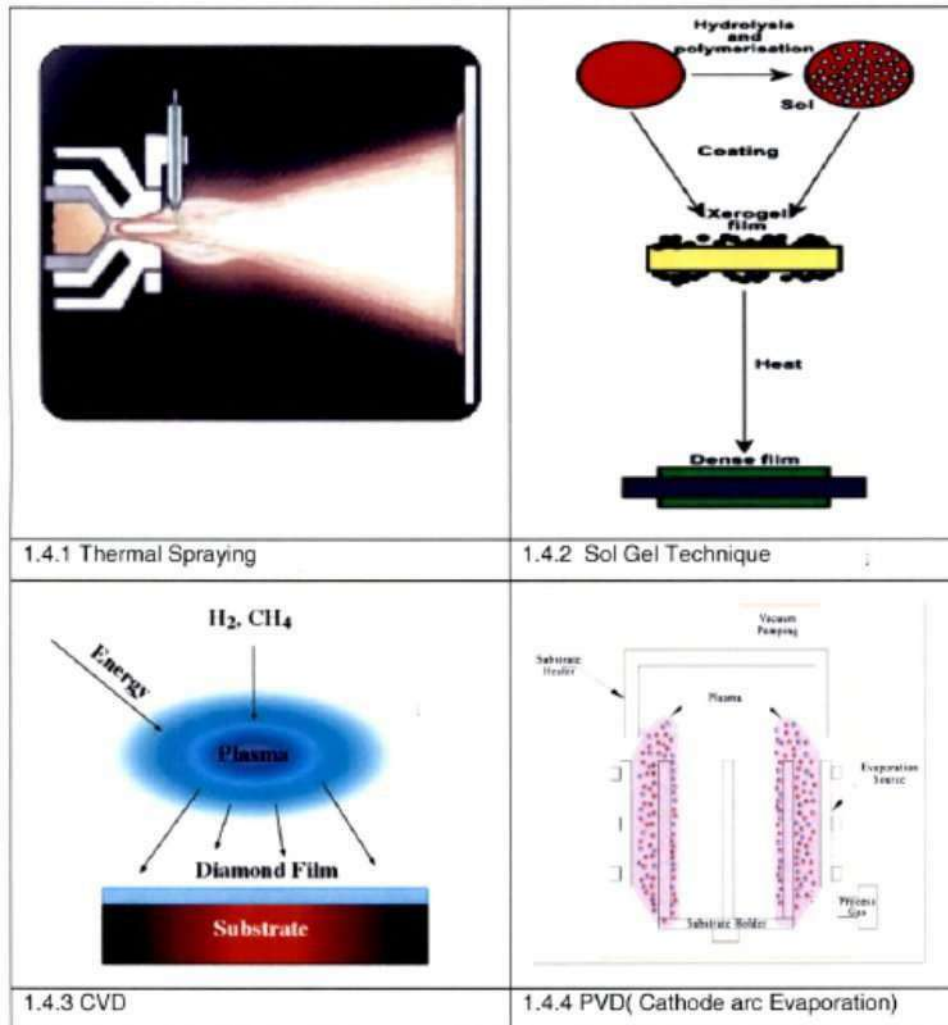

Schematic diagram of various processes for Ceramic thin film deposition

Physical Vapor Deposition Technique (PVD) PVD processes are atomistic deposition processes in which material is vaporized from solid/liquid source in form of atoms/molecules, transported in form of vapor through a vacuum or low pressure gaseous or plasma environment to the substrate where it condenses. PVD can be used to deposit films of metals or alloys as well as compounds using reactive: deposition processes. The main advantage of PVD processes compared to CVD processes is the low deposition temperature (typically around 500°C). Because of low temperature and high growth rates involved PVD coatings have high compressive stresses while those formed under CVD have low tensile

ADVANCE MANUFACTURING PROCESS

stresses. If the layer contains more atoms in interstitial positions than there are vacancies in lattice and tensile stresses are formed like in case of CVD. While if layer contains more Vacancies in interstitial position and atoms in lattice compressive stresses are formed. In Addition to this other advantages include excellent adhesion, good thickness uniformity, wide range of coating and substrate materials is possible and no hydrogen embrittlement problem. PVD Titanium Nitride (TiN) is superior to CVD TiN coating in increasing the metal cutting performance of Cemented carbide tools owing to the former's greater resistance to abrasive wear and its associated higher surface fracture strength. This is due to fact that PVD TiN coating microstructure and beneficial compressive residual stress both of which contribute to higher micro hardness. However main disadvantage of PVD process is they are generally line of sight between surface to be coated and source. PVD thin films are widely used for surface protection, optical and electronic applications. Following figure shows the useage of thin films for various applications.

The largest application of PVD coatings is in surface protection for example in metal cutting field- particularly for twist drills, gear cutting tools, forming tools such as in cold backward impact of copper components, polymer processing machinery (injector screws), moulds for plastic, in food industry coating on stainless steel sleeve used for manufacturing of chocolate, in metrology field thread gauges and slip gauges, in medical applications for surgical tools, used in automotive parts of racing cam. Attractive golden color of TiN has led to its increasing use as decorative coating in jewellery applications. Cathode arc evaporation (CAE), one of the PVD processes has high deposition rates to produce dense and excellent adhesive coatings that offer a potential economical advantage. The industrial utilization of CAE is largely confined to mechanical applications, in particular to the deposition of hard coatings on the cutting tools.

Micro and nano machining of glasses and ceramics

Material removal at micro/nano level with no constraint on the size of the component being machined is called micro or nano machining respectively. Some examples are

- Creating micro features or surface characteristics (especially surface finish) in the micro/nano level.

ADVANCE MANUFACTURING PROCESS

- Removal of material in the form of chips or debris having the size in the range of microns.
- Machining of micro parts is not literally correct as macro machining

The need for high precision in manufacturing was felt by manufacturers worldwide to improve interchangeability of components, improve quality control and longer wear/fatigue life

- In the era of nanotechnology, deterministic high precision finishing methods are of utmost importance and are the need of present manufacturing scenario.
- Final finishing operations in manufacturing of precise parts are always of concern owing to their most critical, labour intensive and least controllable nature

Reverse Engineering,

Engineering is the process of designing, manufacturing, assembling, and maintaining products and systems. There are two types of engineering, forward engineering and reverse engineering. Forward engineering is the traditional process of moving from high-level abstractions and logical designs to the physical implementation of a system. In some situations, there may be a physical part/product without any technical details, such as drawings, bills-of-material, or without engineering data. The process of duplicating an existing part, subassembly, or product, without drawings, documentation, or a computer model is known as reverse engineering. Reverse engineering is also defined as the process of obtaining a geometric CAD model from 3-D points acquired by scanning/digitizing existing parts/products. The process of digitally capturing the physical entities of a component, referred to as reverse engineering (RE), is often defined by researchers with respect to their specific task.

Reverse engineering is now widely used in numerous applications, such as Manufacturing, industrial design, and jewelry design and reproduction. For example, when a new car is launched on the market, competing manufacturers may buy one and disassemble it to learn how it was built and how it works. In software engineering, good source code is often a

ADVANCE MANUFACTURING PROCESS

variation of other good source code. In some situations, such as automotive styling, designers give shape to their ideas by using clay, plaster, wood, or foam rubber, but a CAD model is needed to manufacture the part. As products become more organic in shape, designing in CAD becomes more challenging and there is no guarantee that the CAD representation will replicate the sculpted model exactly.

Reverse engineering provides a solution to this problem because the physical model is the source of information for the CAD model. This is also referred to as the physical-to-digital process depicted in Figure 1.2. Another reason for reverse engineering is to compress product development cycle times. In the intensely competitive global market, manufacturers are constantly seeking new ways to shorten lead times to market a new product.

Rapid product development (RPD) refers to recently developed technologies and techniques that assist manufacturers and designers in meeting the demands of shortened product development time. For example, injection-molding companies need to shorten tool and die development time drastically. By using reverse engineering, a three-dimensional physical product or clay mock-up can be quickly captured in the digital form, remodeled, and exported for rapid prototyping/tooling or rapid manufacturing using multi-axis CNC machining techniques.

Concurrent Engineering

In **concurrent engineering (CE)** product is developed by a team involving engineers from both the design section and the production shop. The advantages of concurrent engineering are based on the economic leverage of addressing all aspects of design of a product as early as possible. Hence using concurrent engineering most of the design modification is incorporated as early as possible. It is also true that the importance of early modification is very significant and the ability of the early change to influence the product cost is much larger as indicated. Hence using concurrent engineering most of the design modifications are incorporated as early as possible.

Rapid prototyping:

Though the principle of concurrent engineering (CE) is quite clear and the advantages of the concept for improved quality and reduced cost are

ADVANCE MANUFACTURING PROCESS

implicit, it is not possible to incorporate CE effectively in the absence of some technique for quick development of prototype. To reduce the development time and adopt concurrent engineering in its true spirit, quick and inexpensive fabrication of prototype parts is essential and rapid prototyping technology has made that possible.

A family of unique fabrication processes developed to make engineering prototypes in minimum lead time based on a CAD model of the item

- The traditional method is machining**

- Machining can require significant lead-times –several weeks, depending on part complexity and difficulty in ordering materials

- RP allows a part to be made in hours or days given that a computer model of the part has been generated on a CAD system

Rapid Prototyping (RP)

Though the principle of concurrent engineering (CE) is quite clear and the advantages of the concept for improved quality and reduced cost are implicit, it is not possible to incorporate CE effectively in the absence of some technique for quick development of prototype. To reduce the development time and adopt concurrent engineering in its true spirit, quick and inexpensive fabrication of prototype parts is essential and rapid prototyping technology has made that possible.

A family of unique fabrication processes developed to make engineering prototypes in minimum lead time based on a CAD model of the item

- The traditional method is machining**

- Machining can require significant lead-times –several weeks, depending on part complexity and difficulty in ordering materials

- RP allows a part to be made in hours or days given that a computer model of the part has been generated on a CAD system

WYSIWYG-What You See Is What You Get

Why Rapid Prototyping?

- Because product designers would like to have a physical model of a new part or product design rather than just a computer model or line drawing

- Creating a prototype is an integral step in design

- A *virtual prototype* (a computer model of the part design on a CAD system) may not be sufficient for the designer to visualize the part adequately

- Using RP to make the prototype, the designer can visually examine and physically feel the part and assess its merits and shortcomings

ADVANCE MANUFACTURING PROCESS

Reverse Engineering:

In today's intensely competitive global market, product enterprises are constantly seeking new ways to shorten lead times for new product developments that meet all customer expectations. In general, product enterprise has invested in CAD/CAM, rapid prototyping, and a range of new technologies that provide business benefits. Reverse engineering (RE) is now considered one of the technologies that provide business benefits in shortening the product development cycle. Figure below depicts how RE allows the possibilities of closing the loop between what is "as designed" and what is "actually manufactured".

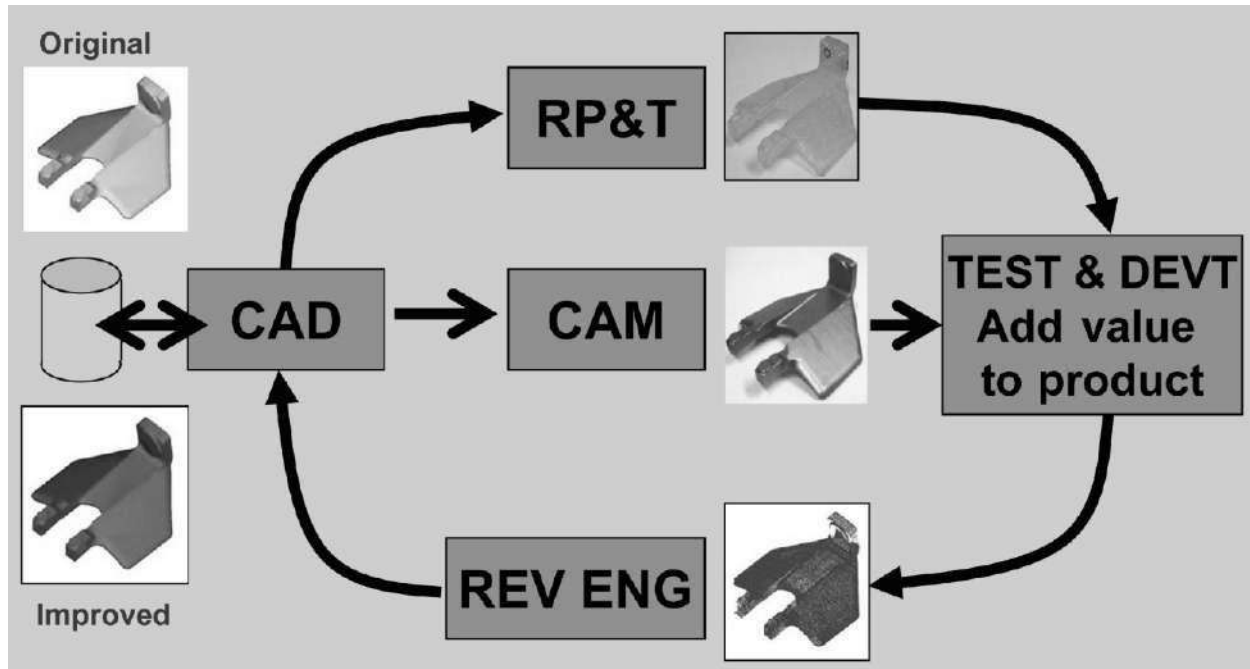

Product development cycle

What Is Reverse Engineering?

Engineering is the process of designing, manufacturing, assembling, and maintaining products and systems. There are two types of engineering, forward engineering and reverse engineering. Forward engineering is the traditional process of moving from high-level abstractions and logical designs to the physical implementation of a system. In some situations, there may be a physical part/product without any technical details, such as drawings, bills-of-material, or without engineering data. The process of duplicating an existing part, subassembly, or product, without drawings,

ADVANCE MANUFACTURING PROCESS

documentation, or a computer model is known as reverse engineering. Reverse engineering is also defined as the process of obtaining a geometric CAD model from 3-D points acquired by scanning/digitizing existing parts/products. The process of digitally capturing the physical entities of a component, referred to as reverse engineering (RE), is often defined by researchers with respect to their specific task.

Reverse engineering is now widely used in numerous applications, such as Manufacturing, industrial design, and jewelry design and reproduction. For example, when a new car is launched on the market, competing manufacturers may buy one and disassemble it to learn how it was built and how it works. In software engineering, good source code is often a variation of other good source code. In some situations, such as automotive styling, designers give shape to their ideas by using clay, plaster, wood, or foam rubber, but a CAD model is needed to manufacture the part. As products become more organic in shape, designing in CAD becomes more challenging and there is no guarantee that the CAD representation will replicate the sculpted model exactly.

Reverse engineering provides a solution to this problem because the physical model is the source of information for the CAD model. This is also referred to as the physical-to-digital process depicted in Figure 1.2. Another reason for reverse engineering is to compress product development cycle times. In the intensely competitive global market, manufacturers are constantly seeking new ways to shorten lead times to market a new product.

Rapid product development (RPD) refers to recently developed technologies and techniques that assist manufacturers and designers in meeting the demands of shortened product development time. For example, injection-molding companies need to shorten tool and die development time drastically. By using reverse engineering, a three-dimensional physical product or clay mock-up can be quickly captured in the digital form, remodeled, and exported for rapid prototyping/tooling or rapid manufacturing using multi-axis CNC machining techniques.

ADVANCE MANUFACTURING PROCESS

Why Use Reverse Engineering?

Following are some of the reasons for using reverse engineering:

- The original manufacturer no longer exists, but a customer needs the product, *e.g.*, aircraft spares required typically after an aircraft has been in service for several years.
- The original manufacturer of a product no longer produces the product, *e.g.*, the original product has become obsolete.
- The original product design documentation has been lost or never existed.
- Creating data to refurbish or manufacture a part for which there are no CAD data, or for which the data have become obsolete or lost.
- Inspection and/or Quality Control—Comparing a fabricated part to its CAD description or to a standard item.
- Some bad features of a product need to be eliminated *e.g.*, excessive wear might indicate where a product should be improved.
- Strengthening the good features of a product based on long-term usage.
- Analyzing the good and bad features of competitors' products.
- Exploring new avenues to improve product performance and features.
- Creating 3-D data from a model or sculpture for animation in games and movies.
- Creating 3-D data from an individual, model or sculpture to create, scale, or reproduce artwork.
- Architectural and construction documentation and measurement.
- Fitting clothing or footwear to individuals and determining the anthropometry of a population.

ADVANCE MANUFACTURING PROCESS

Module - II

Basic principles of RP

- ❖ In this process a solid object with prescribed shape, dimension and finish can be directly produced from the CAD based geometric model data stored in a computer without human intervention.
- ❖ Conventional method for producing parts like casting, forming, machining etc are not suitable for this purpose and a host of new processes for shaping objects directly from the CAD data have been developed and machines are in the market.

Rapid prototyping can be of two types:

- The parts obtained by RP technology can form the prototype directly without requiring any further processing.
- The parts obtained by RP technology can be used to make moulds for casting the prototype component. This type is needed because till today, the commercially available RP machines are non-metallic materials with low strength and low melting temperature.

In general this technology is called as Generative manufacturing Process (GMP) as the shape of the work piece is not obtained by removal of chips or forming or casting. It is achieved by addition of material without any prior recognizable form or shape and no tool is necessary.

In all types of GMPs the CAD model is split into layers as indicated figure below.

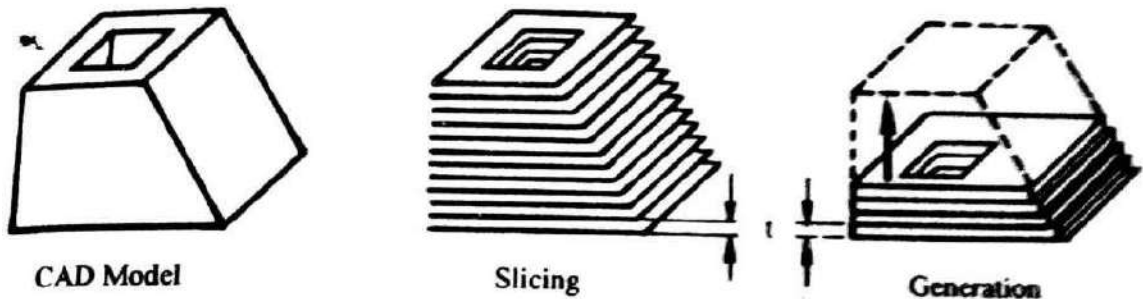

Basic principle of the GMP

ADVANCE MANUFACTURING PROCESS

- ❖ The slice thickness and slicing direction can be varied for convenience of generation.
- ❖ To generate an object of same shape as that of sliced CAD model, the distance between the slicing planes (t) must be equal to the thickness of the corresponding layers during the actual generation process.

The general procedure for obtaining a solid component from a CAD file is shown below:

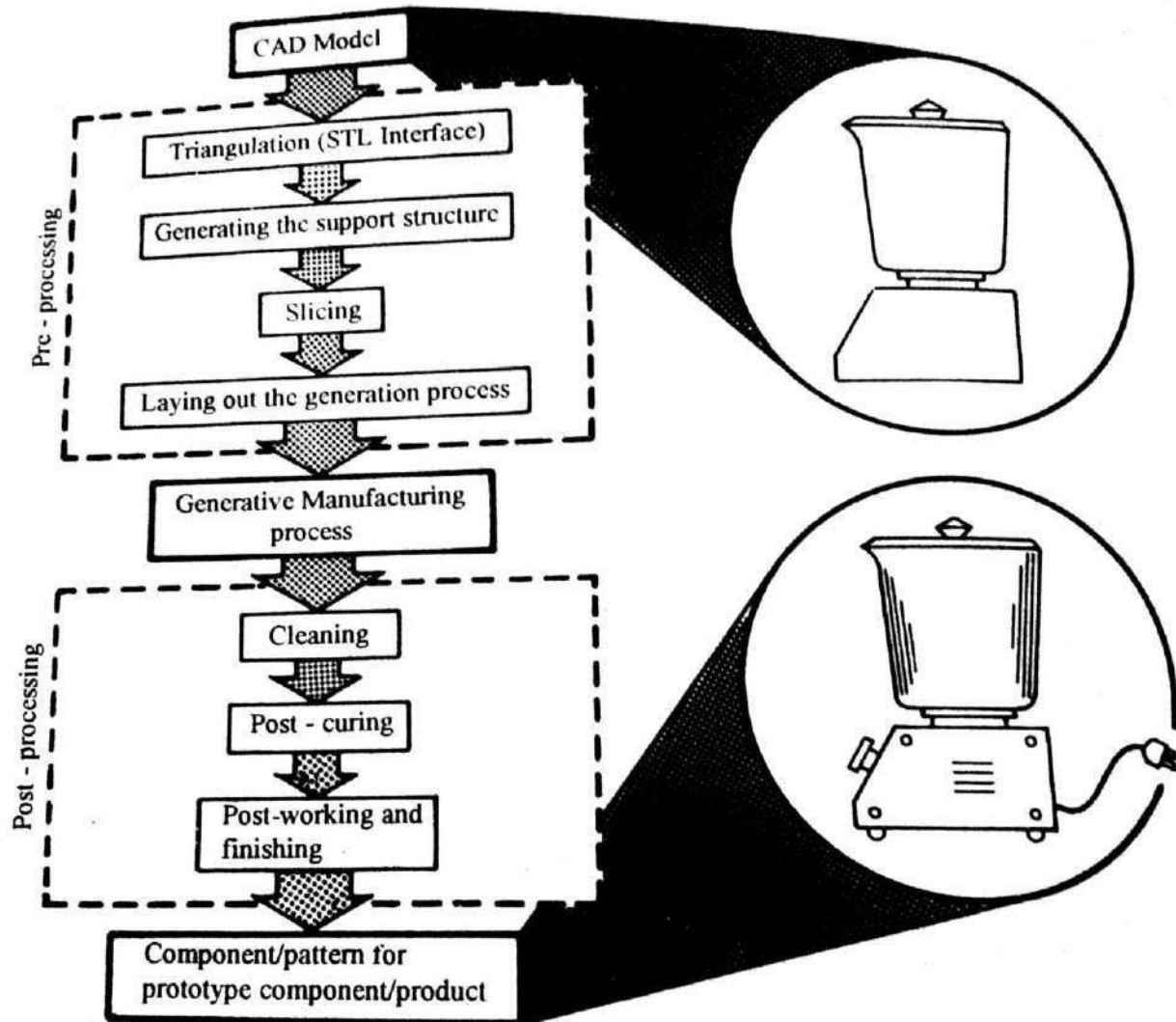

Steps involved in rapid prototyping

ADVANCE MANUFACTURING PROCESS

Process chain in RP in integrated CAD-CAM environment

- ❖ In all commercially developed and technically demonstrated GMP till date the development of part is done by the slicing technique.
- ❖ However a direct 3-dimensional building up technique is also under active consideration. In this technique it will not be necessary to define the part in terms of thin layers and the process will not require the generation of lower part before the upper part is generated.
- ❖ Thus, the freedom and flexibility in shape creation and enhanced, but it puts a great burden on programming the generating equipment.

The figure below shows the whole process chain of rapid product development using RP technique.

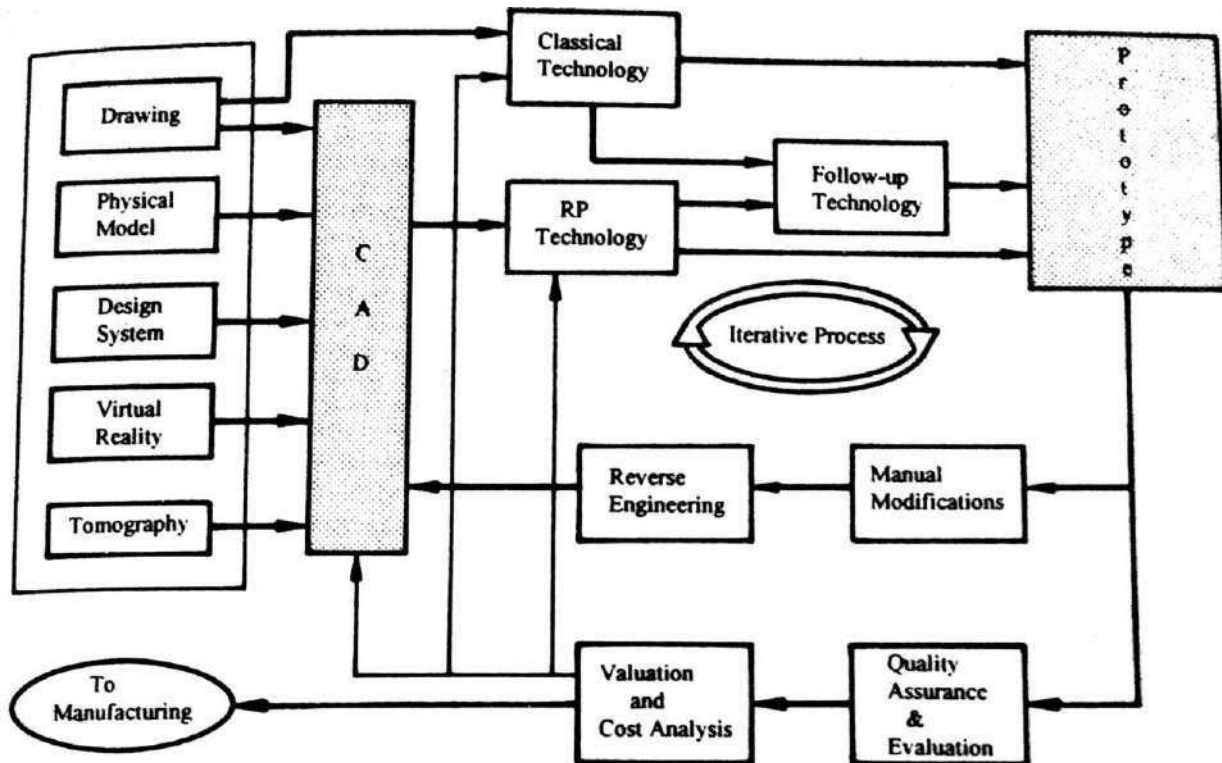

Process chain for rapid prototype development

Advantages and disadvantages of rapid prototyping

Subtractive type RP is typically limited to simple geometries due to the tooling process where material is removed. This type of RP also usually takes a longer time but the main advantage is that the end product is

ADVANCE MANUFACTURING PROCESS

fabricated in the desired material. Additive type RP, on the other hand, can fabricate most complex geometries in a shorter time and lower cost. However, additive type RP typically includes extra post fabrication process of cleaning, post curing or finishing.

Here is some of the general advantages and disadvantages of rapid prototyping :

Advantages:

- ❖ Fast and inexpensive method of prototyping design ideas
- ❖ Multiple design iterations
- ❖ Physical validation of design
- ❖ Reduced product development time

Disadvantages:

- ❖ Resolution not as fine as traditional machining (millimeter to sub- millimeter resolution)
- ❖ Surface flatness is rough (dependent of material and type of RP)

ADVANCE MANUFACTURING PROCESS